

CD-ROM

The CD-ROM, which is inserted in the cover, contains the user manual of the SPX25 **DuCoNite**[®] and SPX32 **DuCoNite**[®] hose pumps. The CD-ROM also contains a replacement instruction for the pump hose. This replacement instruction is only for users that are familiar with the replacement procedures in the user manual.

System requirements

The program on CD-ROM requires a PC with the following minimum system requirements:

- Pentium I 100 MHz
- 64 MB internal memory
- 256 colors

The following software must be installed on the PC:

- Adobe Acrobat Reader
- Internet Explorer

How to use the CD-ROM

- 1 Put the CD-ROM in the CD drive.
- 2 Close the CD drive.
The CD-ROM will start automatically.
- 3 Wait until the various language versions appear on screen.
- 4 Select the required language (click 1x with the left mouse button).
The program Adobe Acrobat Reader will automatically start and the required user manual appears on screen.

Shortcuts

In the left margin you will find the various chapters and paragraphs. These can be accessed directly by clicking on the required chapter or paragraph.

In the text you will find hyperlinks to chapters or paragraphs. These hyperlinks are linked with the required chapters or paragraphs. By clicking a shortcut the required chapter or paragraph appears on screen.

Hose pump series SPX25 and SPX32 *DuCoNite*[®]

Manual

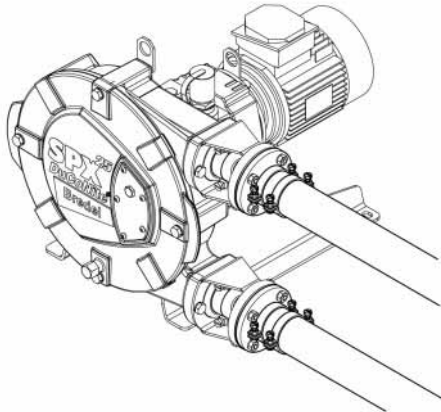

© 2010 Watson-Marlow Bredel B.V.

All rights reserved.

The information provided herein may not be reproduced and/or published in any form, by print, photoprint, microfilm or any other means whatsoever (electronically or mechanically) without the prior written authorisation of Watson-Marlow Bredel B.V.

The information provided can be changed without prior notification. Watson-Marlow Bredel B.V. or one of its representatives cannot be held liable for possible damage resulting from use of this manual. This is an extensive limitation of the liability which applies to all damage, inclusive of (without limitation) compensating, direct, indirect or consequential damage, loss of data, income or profit, loss or damage to possessions and claims of third parties.

Watson-Marlow Bredel B.V. provides the information in this manual "as is" and does not take any responsibility and does not give any guarantee on this manual or its content. Watson-Marlow Bredel B.V. rejects all responsibilities and guarantees. Furthermore, Watson-Marlow Bredel B.V. does not take responsibility for and does not guarantee that the information in this manual is accurate, complete or up to date.

Names, trade names, brands, etc. used by Watson-Marlow Bredel B.V. may not, as per the legislation concerning the protection of trade names, be considered as available.

CONTENTS

1 GENERAL

1.1	<i>How to use this manual</i>	8
1.2	<i>Original instructions</i>	8
1.3	<i>Other supplied documentation</i>	8
1.4	<i>Service and support</i>	8
1.5	<i>Environment and disposal of waste</i>	9

2 SAFETY

2.1	<i>Symbols</i>	10
2.2	<i>Intended use</i>	10
2.3	<i>Use in corrosive atmosphere</i>	11
2.4	<i>Responsibility</i>	11
2.5	<i>Qualification of the user</i>	11
2.6	<i>Regulations and instructions</i>	12

3 WARRANTIES

4 DESCRIPTION

4.1	<i>Identification of the product</i>	14
4.1.1	<i>Identification of the product</i>	14
4.1.2	<i>Identification of the pump</i>	14
4.1.3	<i>Identification of the gearbox</i>	14
4.1.4	<i>Identification of the electric motor</i>	15
4.1.5	<i>Identification of the frequency controller</i>	15
4.1.6	<i>Identification of the pump hose</i>	15
4.2	<i>Construction of the pump</i>	16
4.3	<i>Operation of the pump</i>	17
4.4	<i>Pump hose</i>	18
4.4.1	<i>General</i>	18
4.4.2	<i>Hose compression force adjustment (shimming)</i>	19
4.4.3	<i>Lubrication and cooling</i>	19
4.5	<i>Gearbox</i>	20
4.6	<i>Electric motor</i>	20
4.7	<i>Motor frequency controller</i>	20
4.8	<i>Available options</i>	20

5	INSTALLATION	
5.1	<i>Unpacking</i>	21
5.2	<i>Inspection</i>	21
5.3	<i>Installation conditions</i>	21
5.3.1	Ambient conditions	21
5.3.2	Set-up	21
5.3.3	Pipework	22
5.3.4	Variable Frequency Drive	23
5.3.5	High Level Control (HLC)	24
5.4	<i>Lifting and moving the pump</i>	25
5.5	<i>Placing the pump</i>	25
6	COMMISSIONING	
6.1	<i>Preparations</i>	26
6.2	<i>Commissioning</i>	27
7	MAINTENANCE	
7.1	<i>General</i>	28
7.2	<i>Maintenance and periodic inspections</i>	28
7.3	<i>Cleaning pump hose</i>	30
7.4	<i>Changing lubricant</i>	30
7.5	<i>Changing oil in gearbox</i>	31
7.6	<i>Replacing pump hose</i>	32
7.6.1	Removing pump hose	32
7.6.2	Cleaning the pump head	34
7.6.3	Fitting the pump hose	35
7.7	<i>Exchanging replacement parts</i>	38
7.7.1	Replacing pressing shoes	38
7.7.2	Replacing seal ring and bearings	40
7.8	<i>Adjusting hose compression force (shimming)</i>	43
7.9	<i>Options</i>	45
7.9.1	Revolution counter	45
7.9.2	Drain connection	46
8	STORAGE	
8.1	<i>Hose pump</i>	47
8.2	<i>Pump hose</i>	47

9 TROUBLESHOOTING

10 SPECIFICATIONS

<i>10.1 Pump head</i>	53
10.1.1 Performance	53
10.1.2 Materials	54
10.1.3 Surface treatment	55
10.1.4 Chemical resistance chart DuCoNite® coating	55
10.1.5 Lubricant table pump	56
10.1.6 Weights	56
10.1.7 Torque figures	58
10.1.8 Shims specifications	60
<i>10.2 Lubricant table gearbox</i>	61
<i>10.3 Gearbox</i>	62
<i>10.4 Electric motor</i>	63
<i>10.5 Frequency controller</i>	63
<i>10.6 Parts list</i>	64
10.6.1 Overview	64
10.6.2 Cover assembly	65
10.6.3 Rotor assembly	66
10.6.4 Pump housing assembly	67
10.6.5 Support assembly	69
10.6.6 Flange assembly	70
10.6.7 Revolution counter assembly	71
10.6.8 Lubricants	71

1 GENERAL

1.1 How to use this manual

This manual is intended as a reference book by means of which qualified users are able to install, commission and maintain the hose pumps mentioned on the front cover.

1.2 Original instructions

The original instructions for this manual have been written in English. Other language versions of this manual are a translation of the original instructions.

1.3 Other supplied documentation

Documentation of components such as the motor and the Variable Frequency Drive (VFD) is normally not included in this manual. However, if additional documentation is supplied, you must follow the instructions in this additional documentation.

1.4 Service and support

For information with respect to specific adjustments, installation, maintenance or repair jobs which fall beyond the scope of this manual, contact your Watson-Marlow Bredel representative. Make sure you have the following data at hand:

- Serial number hose pump
- Article number pump hose
- Article number gearbox
- Article number electric motor
- Article number frequency controller

You will find these data on the identification plates or stickers of the pump head, the pump hose, the gearbox and the electric motor. Refer to § 4.1.1.

1.5 Environment and disposal of waste

**CAUTION**

Always observe the local rules and regulations with respect to processing (non reusable) parts of the hose pump.

Inquire within your local government about the possibilities for reuse or environment friendly processing of packaging materials, (contaminated) lubricant and oil.

2 SAFETY

2.1 Symbols

In this manual the following symbols are used:

	<p>WARNING</p> <p>Procedures which, if not carried out with the necessary care, may result in serious damage to the hose pump or in serious bodily harm.</p>
--	---

	<p>CAUTION</p> <p>Procedures which, if not carried out with the necessary care, may result in serious damage to the hose pump, the surrounding area or the environment.</p>
--	--

	<p>Remarks, suggestions and advice.</p>
---	---

2.2 Intended use

The hose pump is exclusively designed for pumping suitable products. Every other or further use is not in conformance with the intended use.

The "Intended use" as laid down in EN 292-1 is "... the use for which the technical product is intended in accordance with the specifications of the manufacturer, inclusive of his indications in the sales brochure". In case of doubt it is the use which appears to be its intended use judging from the construction, execution and function of the product. Observing the instructions in the user's documentation also belongs to intended use.

Only use the pump in accordance with the intended use described above. The manufacturer cannot be held responsible for damage or harm resulting from misuse.

If you want to change the application of your hose pump, contact your Watson-Marlow Bredel representative first.

2.3 Use in corrosive atmosphere

The **DuCoNite**[®] pump head is coated (both internally and externally) with a corrosion and wear resistant coating. This coating withstands oxidizing and reducing media. Refer to § 10.1.4 for a specification.

2.4 Responsibility

The manufacturer does not accept any responsibility for damage or harm caused by not (strictly) observing the safety regulations and instructions in this manual and the also supplied documentation, or by negligence during installation, use, maintenance and repair of the hose pumps mentioned on the front cover. Depending on the specific working conditions or accessories used, additional safety instructions can be required.

Immediately contact your Watson-Marlow Bredel representative, if you noticed a potential danger while using your hose pump.

**WARNING**

The user of the hose pump is always fully responsible for observing the local valid safety regulations and directives. Observe these safety regulations and directives when using the hose pump.

2.5 Qualification of the user

The installation, use and maintenance of the hose pump is only reserved for well trained and qualified users. Temporary staff and persons in training may only use the hose pump under the supervision and responsibility of well trained and qualified users.

2.6 Regulations and instructions

- Everyone who works with the hose pump must be aware of the contents of this manual and observe the instructions with great care.
- Never change the order of the actions to be carried out.
- Always store the manual near the hose pump.

3 WARRANTIES

The manufacturer offers a 2-year warranty on proper workmanship of all parts of the hose pump. Exclusion is made for normal wear and tear of consumables, such as pump hoses, lubricant, hose clamps, pressing shoes, ball bearings, wear ring, and seals, or parts which have been misused or damaged through negligence.

This manufacturer's warranty is null and void for any user who has substituted the parts of an alternate manufacturer into a Watson-Marlow Bredel hose pump.

Damaged parts may be returned to the manufacturer for warranty analysis. If failure was determined caused by faulty workmanship, the manufacturer will repair or replace the faulty component.

The parts must be accompanied by a fully completed and signed health and safety form, as present in the back of this manual. The form must be applied to the outside of the shipping carton.

Parts which have been contaminated or which have been corroded by chemicals or other substances, which can pose a health risk, must be cleaned before they are returned to the manufacturer. Furthermore, it should be indicated on the health and safety form, which specific cleaning procedure has been followed, and it should be indicated that the equipment has been decontaminated. The safety form is required at all items, even if the parts have not been used.

Warranties purporting to be on behalf of Watson-Marlow Bredel B.V. made by any person, including representatives of Watson-Marlow Bredel B.V., its subsidiaries, or its distributors, which do not accord with the terms of this warranty shall not be binding upon Watson-Marlow Bredel B.V. unless expressly approved in writing by a Director or Manager of Watson-Marlow Bredel B.V.

4 DESCRIPTION

4.1 Identification of the product

4.1.1 Identification of the product

The hose pump can be identified based on the identification plates or stickers on:

- A:** Pump head
- B:** Gearbox
- C:** Electric motor
- D:** Pump hose
- E:** Frequency controller (option)

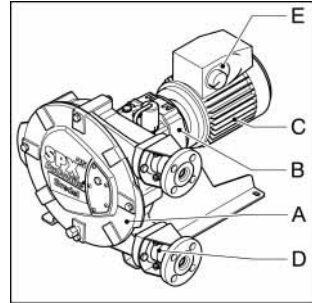

4.1.2 Identification of the pump

The identification plate on the pump head contains the following data:

- A:** Pump model
- B:** Serial number

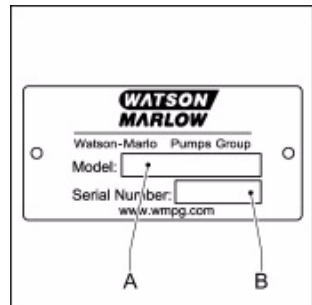

4.1.3 Identification of the gearbox

The identification plate on the gearbox contains the following data:

- A:** Article number
- B:** Serial number
- C:** Type number
- D:** Reduction
- E:** Number of revolutions per minute
- F:** Lubricant type upon delivery

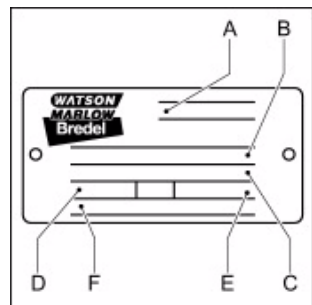

4.1.4 Identification of the electric motor

The identification plate on the electric motor contains the following data:

- A:** Type number
- B:** Serial number
- C:** Article number
- D:** Mains
- E:** Frequency
- F:** Speed
- G:** Power
- H:** Power factor
- I:** Current

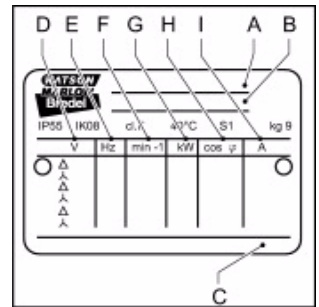

4.1.5 Identification of the frequency controller

The identification plate on the Watson-Marlow Bredel Variable Frequency Drive (VFD) contains the following data:

- A:** Article number

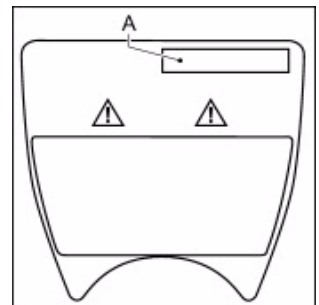

4.1.6 Identification of the pump hose

The identification sticker on the pump hose contains the following data:

- A:** Reorder number
- B:** Internal diameter
- C:** Type of material of inner liner
- D:** Maximum permissible working pressure
- E:** Production code

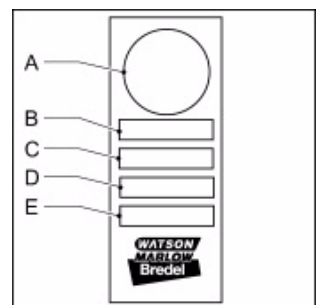

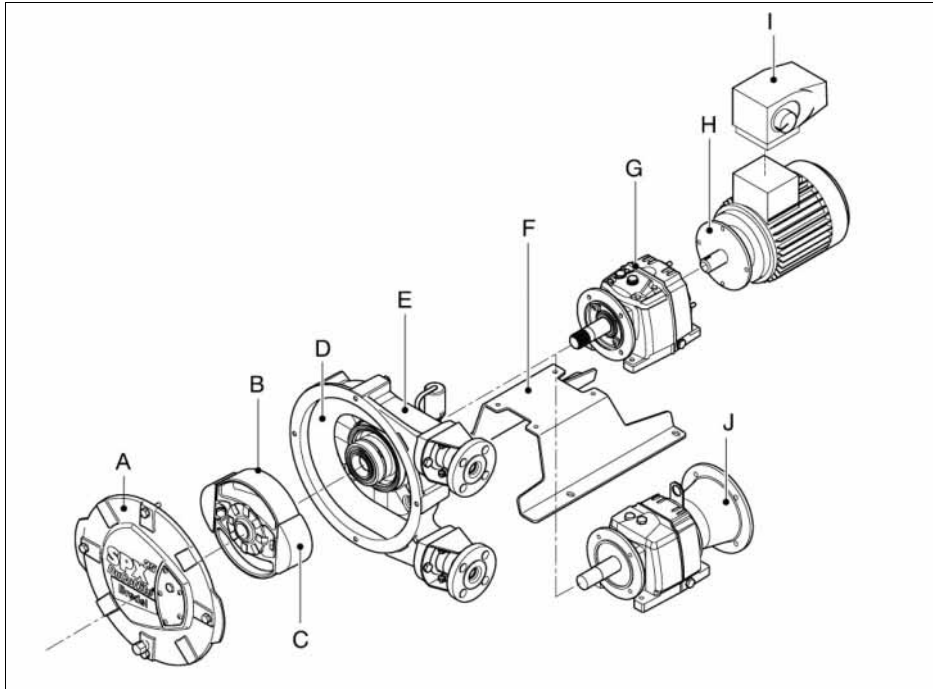
4.2 Construction of the pump

- A:** Cover
- B:** Rotor
- C:** Pressing shoes
- D:** Pump hose
- E:** Pump housing
- F:** Support
- G:** Gearbox
- H:** Electric motor
- I:** Frequency controller (option)
- J:** Adapter without motor (option)

4.3 Operation of the pump

The heart of the pump head consists of a specially constructed pump hose (A) which lies contorted against the inside of the pump housing (B). Both ends of the hose are connected to the suction and discharge lines by means of a flange construction (C). A bearing-mounted rotor (D) with two facing pressing shoes (E) is in the center of the pump head.

In phase 1 the lower pressing shoe compresses the pump hose by the rotational movement of the rotor, forcing the fluid through the hose. As soon as the pressing shoe has passed, the hose recovers to its original shape due to the mechanical properties of the material.

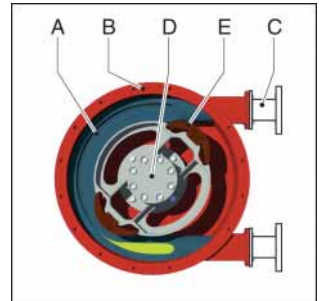

In phase 2 the product is drawn into the hose by the (continuous) turning motion of the rotor.

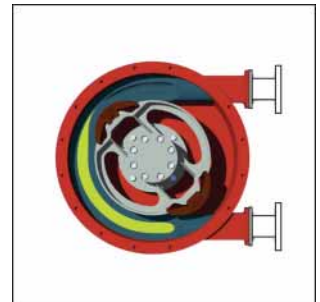

In phase 3, the second pressing shoe will subsequently compress the pump hose. Due to the continuous rotating movement of the rotor not only new product is sucked in, but also the already present product is pressed out by the pressing shoe. When the first pressing shoe runs from the pump hose, the second pressing shoe has already closed the pump hose and the product is prevented from flowing back. This method of liquid displacement is also known as the "positive displacement principle".

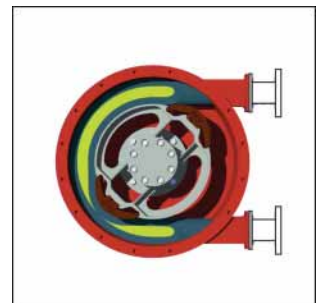

4.4 Pump hose

4.4.1 General

- A:** Outer extruded layer made of natural rubber
B: Four nylon reinforcement layers
C: Inner extruded liner

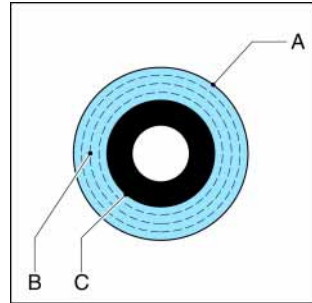

The pump hose liner material should be chemically resistant with the product to be pumped. Dependent on the specific requirements of your application a corresponding pump hose must be selected. For each pump model various hose types are available.

The material of the inner liner of the pump hose determines the hose type. Each hose type is marked by a unique color code.

Hose type	Material	Color code
NR	Natural rubber	Purple
NBR	Buna N	Yellow
EPDM	EPDM	Red
CSM	Hypalon [®]	Blue

	<p>Consult your Watson-Marlow Bredel representative for more detailed information about the chemical and temperature resistance of pump hoses.</p>
--	--

The Watson-Marlow Bredel pump hoses have been carefully machined, therefore there are minimum tolerances in wall thickness. It is very important to guarantee the correct compression of the pump hose, because:

- When the compression is too high, it creates a too high load of the pump and pump hose, which may result in a reduction of the life of the pump hose and bearings.

- When the compression is too low, this will result in loss of capacity and backflow. Backflow results in a reduction of the life of the pump hose.

4.4.2 Hose compression force adjustment (shimming)

In order to achieve optimal life of the pump hose, the compression force of the pump hose can be adjusted by placing a number of shims under the pressing shoes. The shims (A) are fitted between the rotor (B) and the pressing shoe (C). The number of shims will vary for each counterpressure situation.

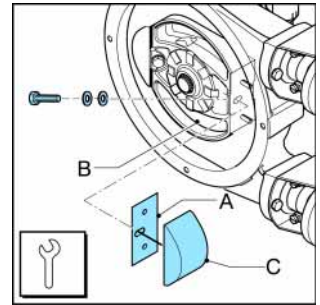

The paragraph [7.8](#) describes how to select and install the shims.

4.4.3 Lubrication and cooling

The pump head, in which the rotor and pump hose can be found, is filled with Watson-Marlow Bredel Genuine Hose Lubricant. This lubricant lubricates the movement between the hose and the pressing shoes and dissipates the generated heat via the pump housing and the cover.

The lubricant is food grade. Refer to § [10.1.5](#) for the required quantity and NSF registration.



Consult your Watson-Marlow Bredel representative for lubrication recommendations when operating the hose pump below 2 rpm.

4.5 Gearbox

The hose pump types described in this manual use coaxial gearbox units.

The gearboxes are fitted with a foot rest. The outgoing shaft has been fitted with a spline.

4.6 Electric motor

If the electric motor has been standard supplied by the manufacturer, it is an integrated standardized squirrel-cage motor. Refer to § [10.4](#) for specifications.

4.7 Motor frequency controller

Refer to the also supplied documentation of the supplier and § [10.5](#).

4.8 Available options

The next options are available for the hose pump:

- High (lubricant) level float switch
- Revolution counter
- Drain connection
- Epoxy / titanium pressing shoes and titanium shims
- Frequency controller

5 INSTALLATION

5.1 Unpacking

When unpacking carefully follow the instructions as given on the packaging or on the hose pump.

5.2 Inspection

Check that your delivery is correct and check it for any transport damage. Refer to § 4.1.1. Report any damage immediately to your Watson-Marlow Bredel representative.

5.3 Installation conditions

5.3.1 Ambient conditions

Make sure that the hose pump is in an area where the ambient temperature during operation is not lower than -4 °F and not higher than +113 °F.

5.3.2 Set-up

- The pump materials and protective layers are suitable for indoor set-up and a protected outdoor set-up. Under certain conditions the pump is suitable for limited outdoor set-up or a salty or aggressive atmosphere. Consult your Watson-Marlow Bredel representative for more information.
- Make sure that the floor surface is horizontal and has a maximum slope of 1 mm per meter (0.012 in per foot).
- Make sure that there is sufficient room around the pump to carry out the necessary maintenance activities.
- Make sure that the room is sufficiently ventilated, so that the heat developed by the pump and drive can be discharged. Keep some

distance between the ventilation cover of the electric motor and wall to enable the supply of necessary cooling air.

5.3.3 Pipework

When determining and connecting suction and discharge lines consider the following points:

- The bore size of the suction and discharge lines must be larger than the bore size of the pump hose. For more information consult your Watson-Marlow Bredel representative.
- Limit the presence of sharp bends in the discharge line. Make sure that the radius of the bent discharge line is as large as possible (preferably 5S). It is recommended to use Y-connections instead of T-connections.
- It is recommended to use a minimum of three quarters (3/4) of the hose length as flexible hose in the suction or discharge line. This avoids the need to remove the connection lines when changing a pump hose.
- Keep the delivery and suction lines as short and direct as possible.
- Select the correct mounting material for flexible hoses and make sure that the installation is suited for the design pressure of the system.
- Prevent any possibilities of exceeding the maximum working pressure of the hose pump. Refer to § 10.1.1. If necessary fit a pressure relief valve.



CAUTION

Consider the maximum permissible working pressure on the discharge side. Exceeding the maximum working pressure may lead to serious damage to the pump.

- Make sure that the maximum forces on the flanges are not exceeded. The permissible loads are given in the following table.

Maximum permissible loads [N] on the pump flange		
Force	SPX25 <i>DuCoNite</i> [®]	SPX32 <i>DuCoNite</i> [®]
F1	600	600
F2	500	500
F3	200	200

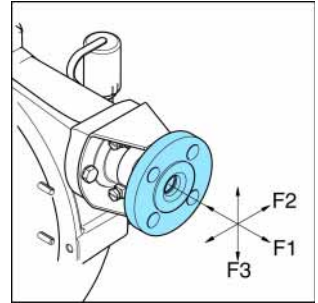

CAUTION

In case of hose failure, the product or a mixture of product and lubricant can leak by the breather cap. If this risk is not acceptable, drain piping can be connected, refer to § 7.9.2.



WARNING

The maximum pump temperature is 140 °F. Above this temperature the corrosion speed can rise excessively, depending on the product.

5.3.4 Variable Frequency Drive



WARNING

A Watson-Marlow Bredel VFD that is fitted *without the control switch* starts automatically when power is applied.

If the hose pump is fitted with a Watson-Marlow Bredel Variable Frequency Drive (VFD), consider the following points:

- Take precautions so the motor does not re-start automatically after an unscheduled stop. In the event of a power or mechanical failure, the Watson-Marlow Bredel VFD controls the motor to stop. When the cause of the failure is

removed, the motor can restart automatically. The automatic restart is dangerous to certain installations of the pump.

- All control cables outside the enclosure must be shielded and have a cross sectional area between 0.22 and 1 mm². The shielding must be connected to earth at both ends.

5.3.5 High Level Control (HLC)

Switch rating: 2 A, 40 VA

To sense the lubricant level inside the pump housing the pump is provisioned with a floater. The HLC floater (A) is positioned above the normal lubricant level of the pump. When a hose fails, the product will be pressed into the pump casing and causes a level rise of the lubricant. The HLC shall detect this rise of lubricant. After hose failure, the floater needs to be cleaned.

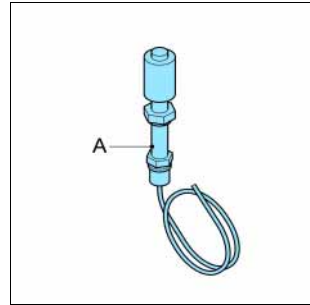

Connection of floaters:

The floater has to be connected to the auxiliary power circuit via the 5 foot long PVC cable (2 x 0.24 mm²).

Specifications	
Voltage:	Max. 230 V AC/DC
Current:	Max. 2 A
Power:	Max. 40 VA

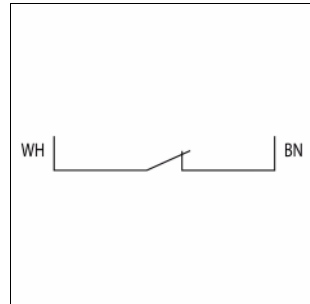

	<p>Where the floater is constructed to stop the equipment, operating has to be arranged so that the stop function locks-out, preventing the equipment from being re-started without re-setting. Check if the floater is mounted with the NC sign at the top.</p>
--	--

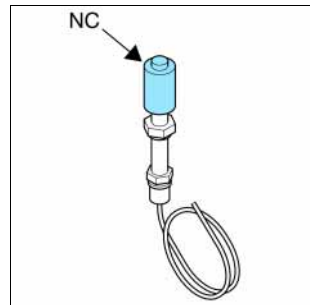

5.4 Lifting and moving the pump

For lifting and moving the *pump head*, it has been fitted with a lifting strip. This lifting strip (A) is fitted on the rear of the pump head. For the weights, refer to § 10.1.6.

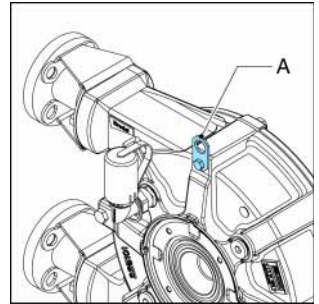

The complete hose pump, i.e. pump head, gearbox and electric motor, must be lifted using the lifting strip of the pump head plus additional support using suitably rated straps or slings (A). For the weights, refer to § 10.1.6.

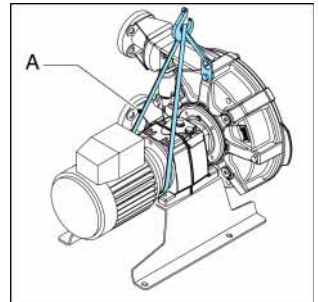

WARNING

If the pump is to be lifted ensure that all standard lifting practices are adhered to and carried out by qualified personnel only.

5.5 Placing the pump

Position the pump on a horizontal surface. Use suitable anchor bolts to attach the pump to the floor surface.

6 COMMISSIONING

6.1 Preparations

**WARNING**

A Watson-Marlow Bredel VFD that is fitted *without the control switch* starts automatically when power is applied.

**WARNING**

Disconnect and lock the power supply to the pump drive before any work is carried out.

Wait two minutes to make sure that the capacitors have discharged. This is necessary when the motor is fitted with a Variable Frequency Drive (VFD) and has single phase power supply.

1. Connect the electric motor and, if present, the frequency controller in conformance with the locally applicable rules and regulations. Refer to § 5.3.4. Have the electrical installation work be carried out by qualified personnel.
2. Check that the lubricant level is above the minimum level line in the inspection window. If necessary refill Watson-Marlow Bredel Genuine Hose Lubricant via the breather/vent plug. See also § 7.4.
3. Check the rotation of the rotor.
4. Check that the correct number of shims corresponds with your application. Refer to § 10.1.8.
For adjusting the compression force of the hose, refer to § 7.8.

6.2 Commissioning

1. Connect the pipework. Make sure that there are no obstructions such as closed valves.
2. Switch on the hose pump.
3. Check the rotation of the rotor.
4. Check the capacity of the hose pump. If the capacity differs from your specification, follow the instructions in chapter 9 or consult your Watson-Marlow Bredel representative.
5. Check the capacity range of the frequency controller. In case of any deviations consult the documentation of the supplier.
6. Check the hose pump in accordance with points 2 to 4 of the maintenance table from § 7.2.

7 MAINTENANCE

7.1 General

	<p>WARNING</p> <p>Disconnect and lock the power supply to the pump drive before any work is carried out.</p> <p>Wait two minutes to make sure that the capacitors have discharged. This is necessary when the motor is fitted with a Watson-Marlow Bredel Variable Frequency Drive (VFD) and has single phase power supply.</p>
--	--

	<p>WARNING</p> <p>Only use original Watson-Marlow Bredel parts when maintaining the hose pump. Watson-Marlow Bredel cannot guarantee correct operation and any consequential damage that occurs from the use of non-original Watson-Marlow Bredel components. See also chapters 2 and 3.</p>
--	---

7.2 Maintenance and periodic inspections

The following diagram shows the maintenance and periodic inspections that need to be carried out on the hose pump to guarantee optimal safety, operation and life of the pump.

Point	Action	To be carried out	Remark
1	Check the lubricant level.	Before startup of the pump and on a scheduled interval during operation.	Make sure that the lubricant level is above the minimum level line in the inspection window. If necessary refill the lubricant. See also § 7.4.
2	Check the pump head for any leakage of lubricant around the cover, the flanges and the rear of the pump head.	Before startup of the pump and on a scheduled interval during operation.	See § 9.
3	Check the gearbox for any leakage.	Before startup of the pump and on a scheduled interval during operation.	In case of leakage consult your Watson-Marlow Bredel representative.
4	Check the pump for deviating temperature or strange noises.	On a scheduled interval during operation.	See § 9.
5	Check the pressing shoes for excessive damage.	When replacing the pump hose.	See § 7.6.
6	Internal cleaning of the pump hose.	Cleaning of the system or product change.	See § 7.3.
7	Replace the pump hose.	Preventive, this means after 75% of the hose life of the first hose.	See § 7.6.
8	Change lubricant.	After every 2 nd hose change or after 5,000 service hours, whichever comes first or after hose rupture.	See § 7.4
9	Change oil in the gearbox.	Refer to the lubricant table in § 10.2.	See § 7.5.
10	Replace the pump seal.	If necessary.	See § 7.7.2.

Point	Action	To be carried out	Remark
11	Check the wear ring.	When the pump seal is replaced, check the running surface of the wear ring for excessive wear.	For replacement, contact your Watson-Marlow Bredel representative.
12	Replace the pressing shoes.	Wear on the running surface.	See § 7.7.1.
13	Replace the bearings.	If necessary.	See § 7.7.2.

7.3 Cleaning pump hose

The inside of the pump hose can be easily cleaned by rinsing the pump with clean water. If a cleaning fluid is added to the water, it must be checked that the hose liner material is resistant to that. Also note that the pump hose can resist the cleaning temperature. Special cleaning balls (pigs) are also available (inform with your Watson-Marlow Bredel representative).

7.4 Changing lubricant

- Place a tray (A) under the drain plug in the cover of the pump. Remove the drain plug (B). Catch the lubricant from the pump housing in the tray.

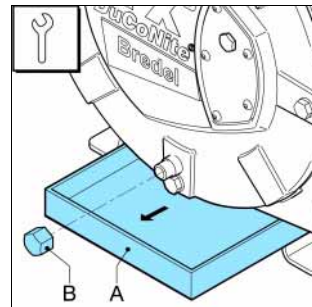

- Position the drain plug (A) and tighten it firmly. In order to facilitate the filling with lubricant the breather plug (B) on the front of the pump housing can be removed.

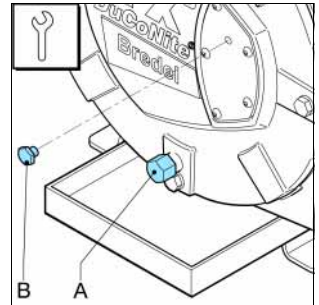

- The pump housing can be filled with lubricant via the breather/vent (A) on the rear of the pump housing. For this purpose remove the breather cap (B) and position a funnel (C) in the breather. Pour the lubricant in the pump housing via the funnel.

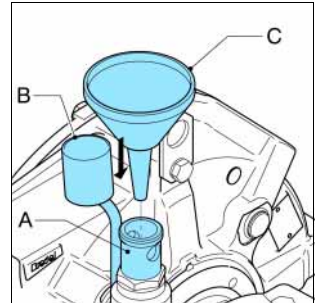

- Keep on pouring until the lubricant level has risen at least until just above the bottom level line in the inspection window. Position the breather plug (A) and tighten it firmly.

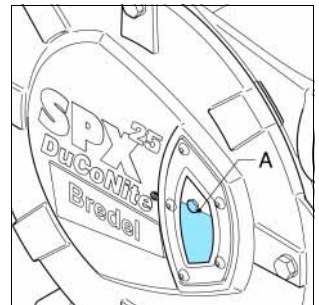

For the required quantity of lubricant, refer to § 10.1.5.

7.5 Changing oil in gearbox

- Isolate the pump from the electrical supply.

2. Remove plug (A) and let the oil run out of the gearbox.
3. The plug (A) is magnetically loaded. In this way metal particles in the oil are pulled to the plug. Clean the plug and remove any metal particles if necessary. Check that the sealing ring is not damaged and replace it if necessary. Place the plug back in the gearbox and tighten it firmly.
4. Remove level plug (B) and filling plug (C) and position a funnel in the hole and fill the gearbox with oil until the oil just comes out of the level plug hole (B). Wait shortly to let out any entrapped air. Place plug (B) and filling plug (C) back and tighten them firmly.

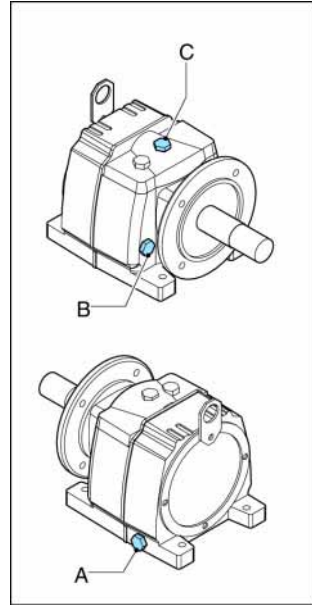

	For the required lubricant, refer to § 10.2.
--	--

5. Switch on the electrical supply to the pump.

7.6 Replacing pump hose

7.6.1 Removing pump hose

1. Isolate the pump from the electrical supply.
2. Close any shut-off valves in both the suction and discharge line to minimize product loss.
3. Place a tray (A) under the drain plug in the bottom of the pump head. The tray must be large enough to contain the lubricant, possibly contaminated with product fluid, from the pump head. Remove the drain plug (B). Catch the lubricant from the pump housing in the tray. Check that the breather/vent mounted on the rear is not obscured. Position the drain plug and tighten it firmly.

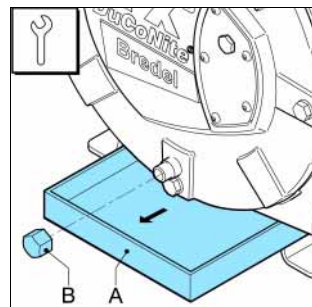

4. Loosen the retaining bolts (A) of both the suction and discharge line (B). Disconnect the suction and discharge lines.

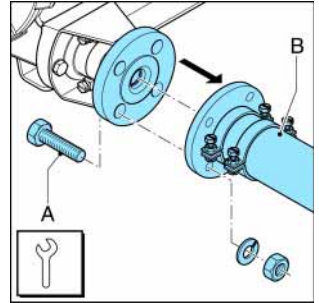

5. Loosen hose clamp (A) of both the inlet and outlet ports by loosening retaining bolt (B).

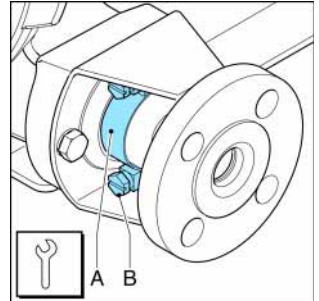

6. Pull the insert (B) from the hose and remove the flanges (A). Carry out this procedure both for the inlet and outlet ports.

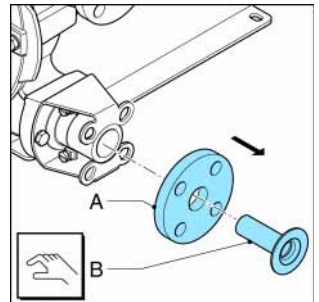

7. Loosen the retaining bolts (A) of the flange bracket (B) and remove the bolts. Slide the flange bracket and the hose clip (C) off the hose. Carry out this procedure both for the inlet and outlet ports.

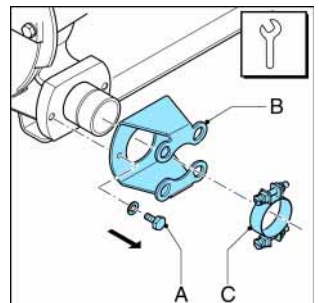

8. Slide off the sealing ring (A). Check that the sealing ring is not deformed or damaged and replace it if necessary. Carry out this procedure both for the inlet and outlet ports.
9. Switch on the electrical supply.
10. Power off the hose (A) from the pump chamber by jogging the drive motor.

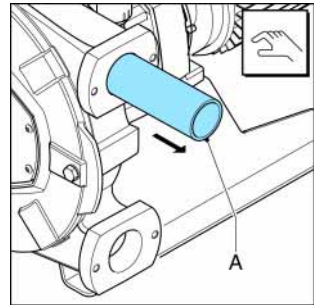
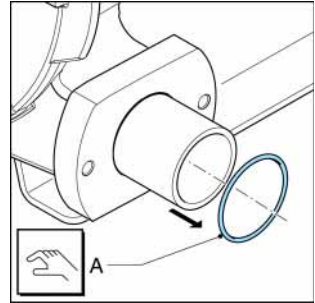

	<p>WARNING</p> <p>During jogging the drive:</p> <ul style="list-style-type: none"> - Do not stand in front of the pump ports. - Do not try to guide the hose by hand.
--	--

7.6.2 Cleaning the pump head

1. Isolate the pump from the electrical supply.
2. Remove the cover (B) by loosening the retaining bolts (A).
3. Check the sealing ring (C) and replace it if necessary.
4. Rinse the pump head with clean water and remove all residues. Make sure that no rinsing water remains in the pump head.

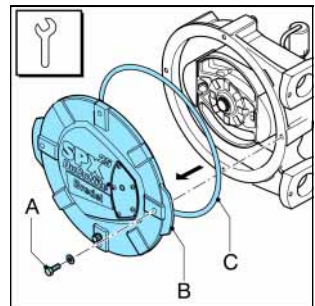

5. Check the pressing shoes for wear or damage and replace them if necessary. Refer to § 7.7.1. Also see the maintenance diagram in § 7.2.

**CAUTION**

When the pressing shoes are worn the compression force of the hose decreases. If the compression force is too low, this results in a loss of capacity by the backflow of the liquid to be pumped. Backflow results in a reduction of the life of the pump hose.

6. Replace the cover and fasten the retaining bolts with the correct torque. Refer to § 10.1.7.
7. Switch on the electrical supply to the pump.

7.6.3 Fitting the pump hose

1. Clean the (new) pump hose on the outside and fully lubricate it with Watson-Marlow Bredel Genuine Hose Lubricant.
2. Fit the pump hose (A) via one of the ports.
3. Let the motor run to pull the hose in the pump housing. The rotor will take up the hose. Stop the motor when the hose sticks out equally from both sides of the pump housing.

**WARNING**

During jogging the drive:

- Do not stand in front of the pump ports.
- Do not try to guide the hose by hand.

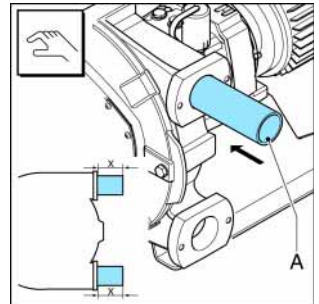

4. First fit the inlet port. Fit the sealing ring. Before mounting, check that the sealing ring (A) is not deformed or damaged and replace it if necessary.

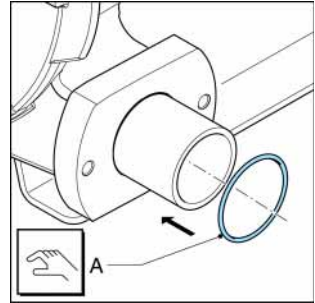

5. Before fitting check that the hose clamp is not damaged and replace it if necessary. Slide the flange bracket (B) and the hose clamp (C) over the hose together. Align the holes in the flange bracket with the ones at the front of the port. Position the two retaining bolts (A) and tighten them until they are approx. 5 mm (3/16") from the port, so that the gap between the flange bracket and the port remains.

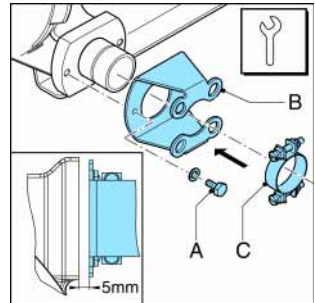

6. Slide insert (B) in flange (A) and press the insert in the hose. If necessary lubricate the insert with Watson-Marlow Bredel Genuine Hose Lubricant in order to simplify mounting. Make sure that the holes in flange (A) are aligned with the holes in flange bracket (C). Check that the insert is in the correct place. If the insert is not positioned correctly the product to be pumped may leak or the lubricant may leak.

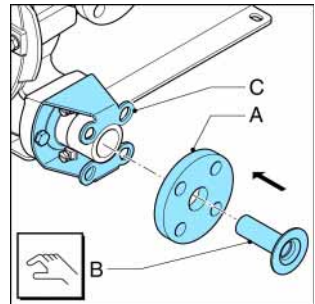

7. Fit the suction line (B) and the retaining bolts (A). Tighten the retaining bolts with the correct torque. Refer to § 10.1.7.

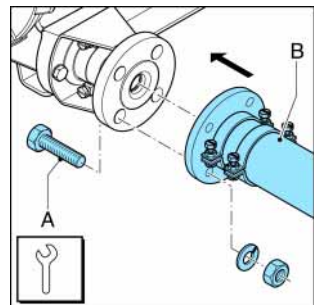

8. Turn the rotor in such a way that the hose (A) is pressed firmly against the flange surface (B).

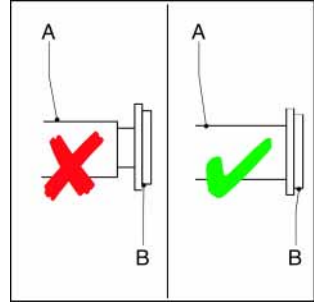

9. Now fully tighten the retaining bolts (A) of the flange bracket (B). Make sure the bolts are tightened with the correct torque. Refer to § 10.1.7.

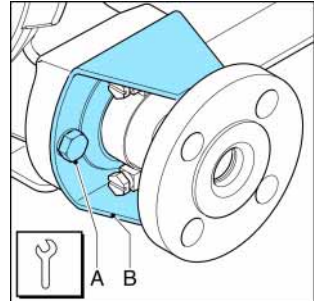

10. Position hose clamp (A) against O-ring chamber of the flange bracket (B) and fasten the retaining bolt. Make sure the bolts are tightened with the correct torque. Refer to § 10.1.7.

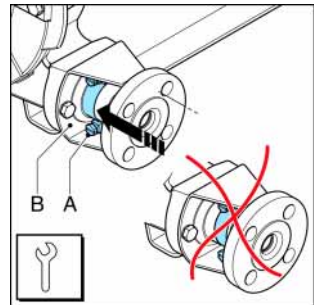

11. Now fit the other port. For this port proceed in the same way as described above for the inlet port.

12. Fill the pump housing with Watson-Marlow Bredel Genuine Hose Lubricant. Refer to § 7.4.

7.7 Exchanging replacement parts

7.7.1 Replacing pressing shoes

1. Jog the motor until the pressing shoe (B) is positioned between the inlet and outlet port (A).
2. Isolate the pump from the electrical supply.

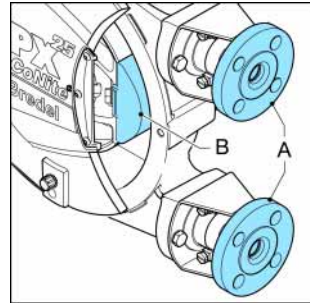

3. Place a tray (A) under the drain plug in the cover of the pump. Remove the drain plug (B). Catch the lubricant from the pump housing in the tray. Position the drain plug and tighten it firmly.

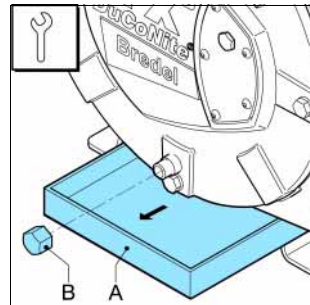

4. Remove the cover (A) by loosening the four retaining bolts (B).

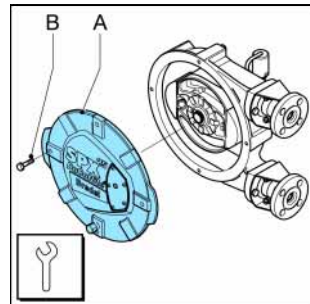

5. Loosen the retaining bolt (A) of the pressing shoe (B). Remove the shims (C) if present.

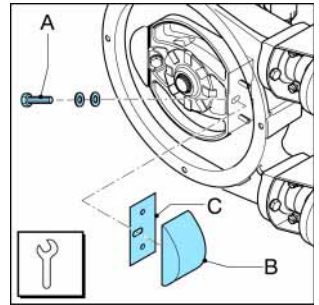

6. Fit the removed shims (C) again. Position the (new) pressing shoe (B), check that the Nord-Lock® rings (D) have been positioned correctly and tighten the retaining bolt(s) (A) a few turns. Refer to § 10.1.7.

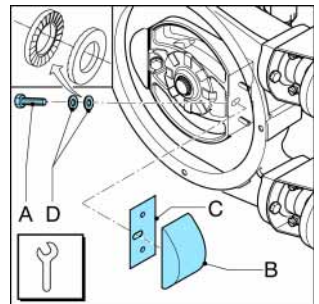

7. Check the gasket (C) for damage and replace if necessary. Refit the cover (B). Make sure that the 4 bolts (A) are refitted and that they are tightened in the correct order, diagonally opposite each other. Refer to § 10.1.7.

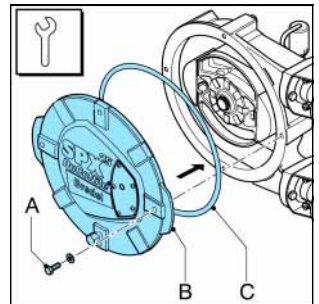

8. Switch on the electrical supply.
9. Jog the motor until the second pressing shoe is positioned between the inlet and outlet port.
10. Isolate the pump from the electrical supply.
11. Repeat the procedure for removing and fitting this second pressing shoe by repeating steps 4 through 8.
12. Refill the lubricant. Refer to § 7.4.

7.7.2 Replacing seal ring and bearings

1. Remove the pump hose. Refer to § 7.6.1.
2. Isolate the pump from the electrical supply.
3. Remove the cover (B) by loosening the retaining bolts (A).
4. Check the sealing ring (C) and replace it if necessary.
5. Loosen the retaining bolt (A) of both pressing shoes (B). Remove the shims (C) if present.
6. Extract the rotor (A) from the hub. Position both crow bars behind the recesses (B) in the rotor.

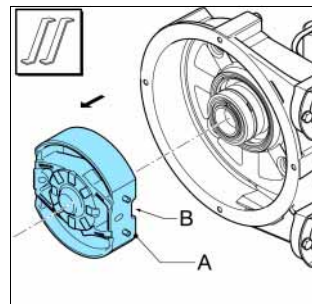
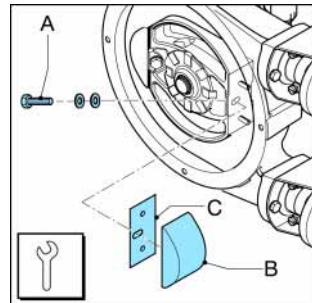
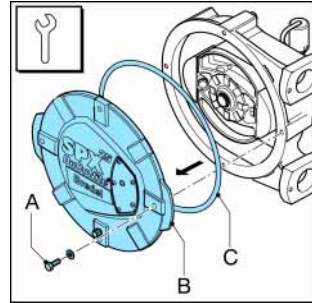

7. Dismount the retaining circlip (A) with the correct tool.

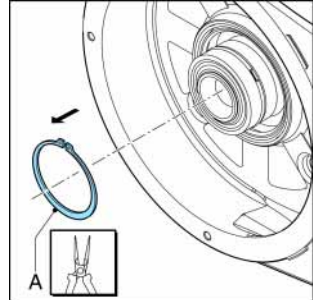

8. Dismount the bearings (A) with the correct tool, the spacer ring (B) and the retaining circlip (C).

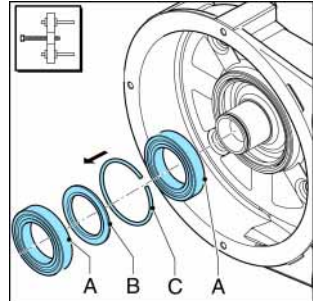

9. Remove the seal (A). Clean and degrease the bore.

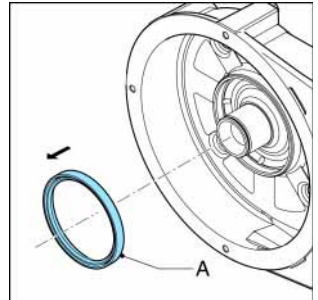

10. Fit a new seal (A) using good engineering practises. The seal must be fitted in the correct orientation (B). Make sure that the open side points to the pump cover.

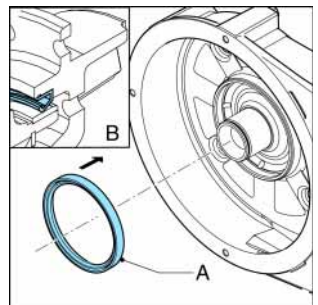

11. Check that the hub is clean and free of grease. Fit the bearings and the rings now. The bearings are placed on the hub with a slight interference fit. Use a pressing tool to press the bearings on the hub.

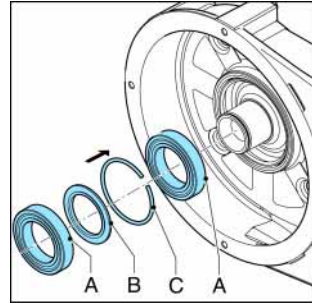

12. Mount the retaining circlip (A).

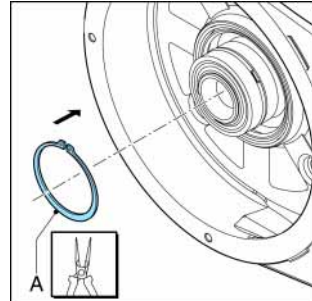

13. Fit rotor (A). The rotor is placed on the bearings with a loose fit. Press the rotor on the hub until it sticks.

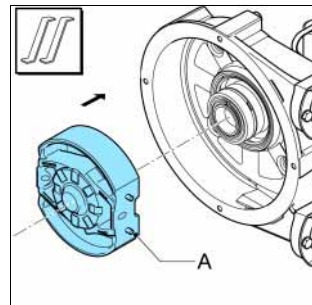

14. Fit the removed shims (C) again. Position the (new) pressing shoe (B), check that the Nord-Lock® rings (D) have been positioned correctly and tighten the retaining bolt(s) (A) a few turns. Refer to § 10.1.7.

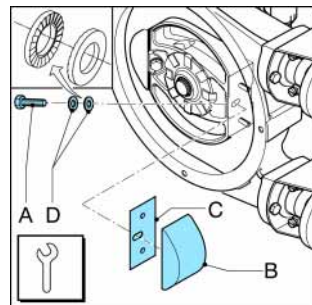

15. Check the gasket (C) for damage and replace if necessary. Refit the cover (B). Make sure that the 4 bolts (A) are refitted and that they are tightened in the correct order, diagonally opposite each other. Refer to § 10.1.7.
16. Switch on the electrical supply to the pump.
17. Fit the (new) pump hose. Refer to § 7.6.3.

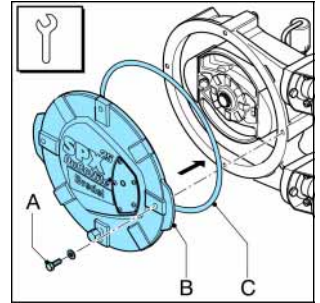

7.8 Adjusting hose compression force (shimming)

Remove the pump cover before fitting and removing shims. In order to determine the correct number of shims for your specific application refer to § 10.1.8.



CAUTION

Too many shims, this means a too high compression force on the pump hose, will create a too high load on the pump head and pump hose, which may result in a reduction of the life of the pump hose and bearings.



CAUTION

Too few shims, this means a too low compression force on the pump hose, create a loss of yield and slip or backflow. Backflow results in a reduction of the life of the pump hose.

1. Jog the motor until the pressing shoe (B) is positioned between the inlet and outlet port (A).
2. Isolate the pump from the electrical supply.

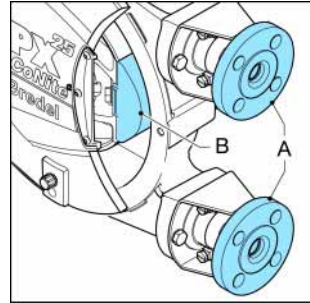

3. Place a tray (A) under the drain plug in the cover of the pump. Remove the drain plug (B). Catch the lubricant from the pump housing in the tray. Position the drain plug and tighten it firmly.

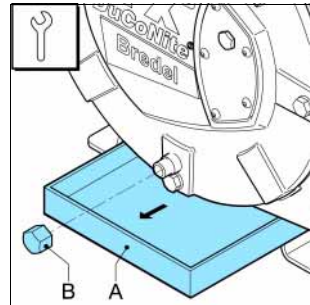

4. Remove the cover (B) by loosening the retaining bolts (A).

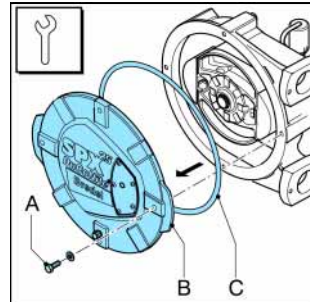

5. Loosen the retaining bolt (A) of the pressing shoe (B). Fit the shims (C) or remove them, until the correct number of shims is present. Refer to § 10.1.8. Fasten the retaining bolt of the pressing shoe with the correct torque. Refer to § 10.1.7.

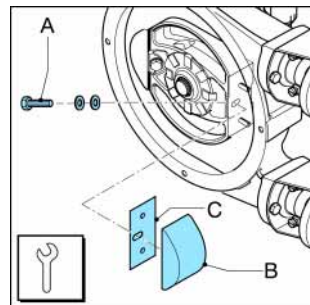

6. Refit the cover (B). Check the gasket (C) for damage and replace if necessary. Make sure that all bolts (A) are refitted and that they are tightened in the correct order, diagonally opposite each other. Refer to § 10.1.7.
7. Switch on the electrical supply.
8. Jog the rotor until the second pressing shoe is positioned between the inlet and outlet port.
9. Isolate the pump from the electrical supply.
10. Repeat the procedure for this pressing shoe by repeating steps 4, 5, 6 and 7.
11. Refill the lubricant via the breather. Refer to § 7.4.

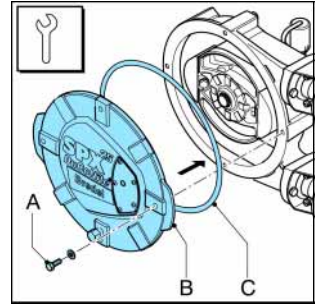

7.9 Options

7.9.1 Revolution counter

For feedback of the pump revolutions to an "intelligent" system, the pump can be provided with an inductive sensor (A). This sensor is mounted at the backside of the pump.

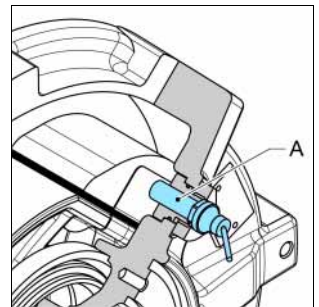

Connection of the revolution counter:

The speed sensor can be connected via the 7 foot long PVC cable (3 x 0.34 mm²).

Specifications	
Voltage:	10...30 VDC
Current:	Max. 200 mA

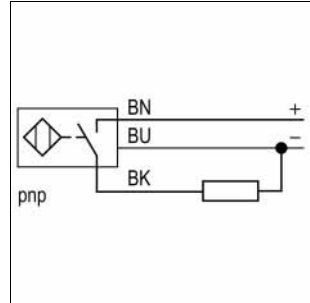

Adjustment sensor:

The sensor (A) must be adjusted at an offset of 1-2 mm to the special shim (B).

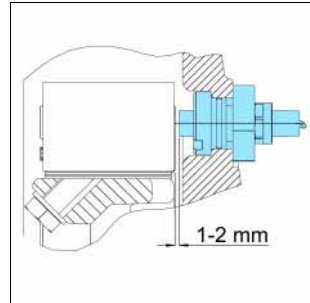

7.9.2 Drain connection

Drain piping can be connected with an optional part (A) fitted at the breather. This is a 1" NPT threaded connection.

	<p>CAUTION</p> <p>The drain piping must be connected to an open reservoir, to prevent pressure built up inside the pump housing.</p>
--	---

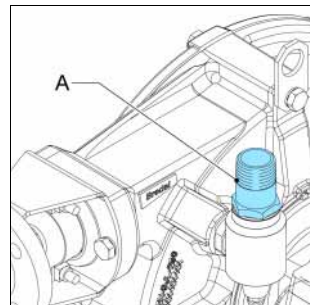

8 STORAGE

8.1 Hose pump

- Store the hose pump or pump parts in a dry area. Make sure that the hose pump or pump parts are not exposed to temperatures lower than -40 °F or higher than +140 °F.
- Cover the openings of the inlet and outlet ports.
- Prevent corrosion of untreated parts. For this purpose use the correct protection or packaging means.
- After a long period of standstill or storage, the static load on the pump hose may have caused permanent deformation, which will reduce the life of the pump hose. To prevent this, remove a pressing shoe. Jog the rotor until the second pressing shoe is positioned between the inlet and outlet port. In this way there is no load put on the pump hose.

8.2 Pump hose

- Store the pump hose in a cool and dark room. After 2 years the hose material will age, which will reduce the life of the hose.

9 TROUBLESHOOTING



WARNING

Disconnect and lock the power supply to the pump drive before any work is carried out.

Wait two minutes to make sure that the capacitors have discharged. This is necessary when the motor is fitted with a Variable Frequency Drive (VFD) and has single phase power supply.

If the hose pump does not function (correctly), consult the following checklist to see if you can remedy the error yourself. If this is not the case, contact your Watson-Marlow Bredel representative.

Problem	Possible cause	Correction
Failure to operate.	No voltage.	Check that the supply power switch is on.
		Check the electrical supply is available at the pump.
	Stalled rotor.	Check if the pump is stalled by incorrect fitting of the hose.
	Lubricant level monitoring system has been activated.	Check that the lubricant level monitoring system has stalled the pump. Check the functioning of the lubricant level monitoring system, or check the lubricant level.

Problem	Possible cause	Correction
High pump temperature.	Non standard hose lubricant used.	Consult the Watson-Marlow Bredel representative for the correct lubricant.
	Low lubricant level.	Add Watson-Marlow Bredel Genuine Hose Lubricant. For the required amount of lubricant refer to § 10.1.5.
	Product temperature too high.	Consult the Watson-Marlow Bredel representative about the maximum temperature range of the product.
	Internal friction on the hose caused by blocked or poor suction characteristics.	Check pipework/valves for blockages. Ensure that the suction pipework is as short as possible and that the diameter is large enough.
	Over-shimming of the pump rotor shoes.	Consult the diagram. Refer to § 10.1.8. Remove excess shims.
	High pump speed.	Reduce pump speed to a minimum. Consult with your Watson-Marlow Bredel pump representative for advice on optimum pump speeds.

Problem	Possible cause	Correction
Low capacity / pressure.	Shut-off valve in the suction line (partly) closed.	Fully open the shut-off valve.
	Under shimming of the pressing shoes.	Consult the diagram in § 10.1.8. Fit the correct number of shims.
	Hose rupture or badly worn hose.	Replace hose. Refer to § 7.6.
	(Partial) blockage of the suction line or too little product on the suction side.	Ensure that the suction line is clear of blockages and that sufficient product is available.
	Connections and hose clamps not correctly mounted, which makes the pump suck air.	Tighten connections and hose clamps.
	The filling degree of the pump hose is too low, because the speed is too high in relation to the viscosity of the product to be pumped and the inlet pressure. The suction line can be too long or too narrow or a combination of these factors.	Consult your Watson-Marlow Bredel representative for a recommendation.

Problem	Possible cause	Correction
Vibration of the pump and pipework.	Suction and discharge lines are not secured correctly.	Check and secure pipe-work.
	High pump speed with long suction and discharge lines or high relative density or a combination of these factors.	Reduce pump speed. Reduce the line lengths on both suction and discharge where possible. Consult your Watson-Marlow Bredel representative for a recommendation.
	Too narrow diameter of suction and/or discharge line.	Increase the diameter of the suction/discharge lines.
Short hose life.	Chemical attack of the hose.	Check the compatibility of the hose material with the product to be pumped. Consult your Watson-Marlow Bredel representative for correct hose selection.
	High pump speed.	Reduce pump speed.
	High discharge pressures.	Maximum working pressure 1600 kPa (232 psi). Check that the discharge line is not blocked, the shut-off valves are fully opened and the pressure relief valve functions properly (if present in the discharge line).
	High product temperature.	Consult your Watson-Marlow Bredel representative for correct hose selection.
	High pulsations.	Restructure the discharge and inlet conditions.

Problem	Possible cause	Correction
Hose pulled into the pump.	Insufficient or no hose lubricant in the pump head.	Add extra lubricant. Refer to § 7.4.
	Incorrect lubricant: no Watson-Marlow Bredel Genuine Hose Lubricant in the pump head.	Consult the Watson-Marlow Bredel representative for the correct lubricant.
	Extremely high inlet pressure - larger than 300 kPa (43.5 psi).	Reduce the inlet pressure.
Lubricant leakage at flange bracket.	Hose blocked by an incompressible object in the hose. The hose cannot be compressed and will be pulled into the pump housing.	Remove hose, check for blockages and replace if necessary.
	Bolts of flange bracket loose.	Tighten to the specified torque settings. Refer to § 10.1.7.
	Bolts of hose clamps loose.	Tighten to the specified torque settings. Refer to § 10.1.7.
Leakage from the rear of the pump housing "Buffer zone".	Damaged sealing ring.	Replace sealing ring.
Motor functions, but rotor does not.	Broken fracture surface on rotor.	Replace the rotor.
Extreme corrosion inside the pump	When the pump temperature goes above 140 °F, the corrosion speed can rise excessively, depending on the product.	Lower the pump temperature, by using the pump intermittently. Or mount a temperature switch, to prevent the pump temperature to rise above 140 °F.

10 SPECIFICATIONS

10.1 Pump head

10.1.1 Performance

Description	Unit	SPX25 <i>DuCoNite</i> [®]	SPX32 <i>DuCoNite</i> [®]
Max. capacity, continuous	m ³ /h	1.80	3.25
	gpm	7.92	14.31
Max. capacity, intermittently*	m ³ /h	2.88	5.25
	gpm	12.68	23.12
Capacity per revolution	l/rev	0.300	0.625
	gal/rev	0.079	0.165
Max. permissible working pressure	kPa	1600	
	psi	232	
Permissible ambient temperature	°C	-20 to +45	
	°F	-4 to +113	
Permissible product temperature	°C	-10 to +60	
	°F	+14 to +140	
Sound level at 1 m (3.3 ft)	dB(A)	70	

* Intermittent duty: "Let the pump stand still to cool down for at least 1 hour after 2 hours of operation".

10.1.2 Materials

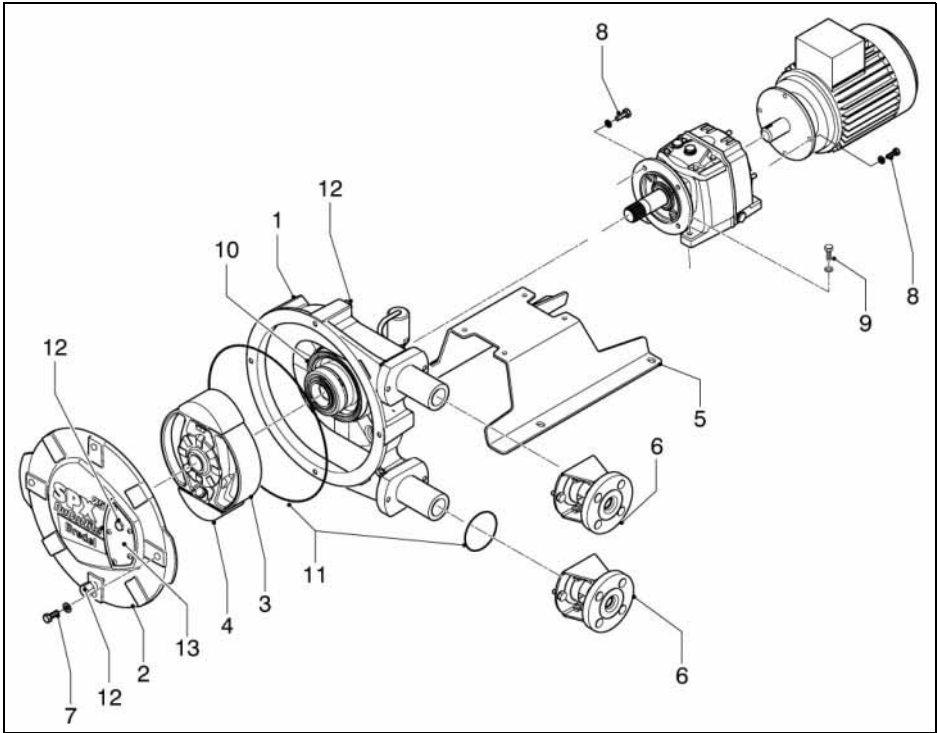

Pos	Description	Material
1	Pump housing	Cast-iron
2	Cover	Cast-iron
3	Pump rotor	Cast-iron
4	Pressing shoe	Epoxy
5	Pump support	AISI 316
6	Flange bracket	AISI 316
7	Mounting material of pump cover	AISI 316
8	Mounting material of drive system	AISI 316
9	Mounting material of pump support	AISI 316
10	Seal	VITON
11	Seals, gaskets	EPDM
12	Fitting	PVC
13	Inspection cover	PVC

10.1.3 Surface treatment

Pump head

The main pump head parts (pump housing, cover and rotor) are provided with a special **DuCoNite[®]** coating, which is both chemical and wear resistant. For the chemical resistance chart refer to § 10.1.4.

Gearbox-electric motor

After surface preparation, one layer of 2-component acrylate is used for surface protection. The standard color is RAL 9005. Contact your Watson-Marlow Bredel representative for details on surface treatment.

10.1.4 Chemical resistance chart **DuCoNite[®]** coating

Chemical	Concentration	Chemical compatibility ¹ with DuCoNite[®]	Hose material
Sodium Hypochlorite	up to 18%	A	EPDM
Sodium Bisulphate	38%	A	EPDM
Ferric Chloride	up to 50%	A	EPDM
Ferrous Chloride	35%	A	EPDM
Alum	50%	A	EPDM
Polymer		A	EPDM
Fluoride (Hydrofluorosilicic Acid)	18-24%	B	EPDM
Sodium Hydroxide	20-50%	A	EPDM
Potassium Permanganate	50%	A	EPDM
Potassium Hydroxide	up to 70%	A	EPDM
Aqueous Ammonia	20%	B	EPDM
Methanol		A	EPDM
Sulfuric Acid	93-97%	A	CSM
Peroxide	50%	A	CSM
Citric Acid	50%	A	EPDM
Zinc Orthophosphate	25%	A	EPDM

Chemical	Concentration	Chemical compatibility ¹ with DuCoNite®	Hose material
Phosphoric Acid	50%	A	EPDM
Nitric Acid	25%	B	CSM

If the ambient temperature is above 104 °F consult your Watson-Marlow Bredel representative.

¹⁾ Chemical compatibility:
 A = good
 B = limited

10.1.5 Lubricant table pump

	Unit	SPX25 DuCoNite®	SPX32 DuCoNite®
Lubricant	-	Watson-Marlow Bredel Genuine Hose Lubricant	Watson-Marlow Bredel Genuine Hose Lubricant
Required quantity	l	2.5	4.5
	gal	0.7	1.2

Watson-Marlow Bredel Genuine Hose Lubricant is registered at NSF: NSF Registration N° 123204; Category Code H1. See also: www.NSF.org/USDA.

	Should you require additional information with respect to the safety data sheet, consult your Watson-Marlow Bredel representative.
--	--

10.1.6 Weights

Description	Unit	Weight	
		SPX25 DuCoNite®	SPX32 DuCoNite®
Main components:			
Pump head	kg	55	82
	lbs	121	180.4
Gearbox	kg	14.5	20
	lbs	31.9	44

Description	Unit	Weight	
		SPX25 DuCoNite®	SPX32 DuCoNite®
Motor	kg	11 - 17	11 - 23
	lbs	24.2 - 37.4	24.2 - 50.6
Total unit:	kg	81 - 87	113 - 125
	lbs	178.2 - 191.4	248.6 - 275
Components:			
Hose	kg	2	3
	lbs	4.4	6.6
Lubricant	kg	3	5.5
	lbs	6.6	12.1
Gearbox G0311...	kg	14.5	
	lbs	31.9	
Gearbox G0321...	kg	14.5	
	lbs	31.9	
Gearbox G0361...	kg		20
	lbs		44
Gearbox G0371...	kg		20
	lbs		44
Motor 0.55 kW, E013201	kg	11	
	lbs	24.2	
Motor 0.75 kW, E013211	kg	11	
	lbs	24.2	
Motor 1.1 kW, E013221	kg	15	
	lbs	33	
Motor 1.5 kW, E013231	kg	17	
	lbs	37.4	
Motor 2.2 kW, E013241	kg	23	
	lbs	50.6	

10.1.7 Torque figures

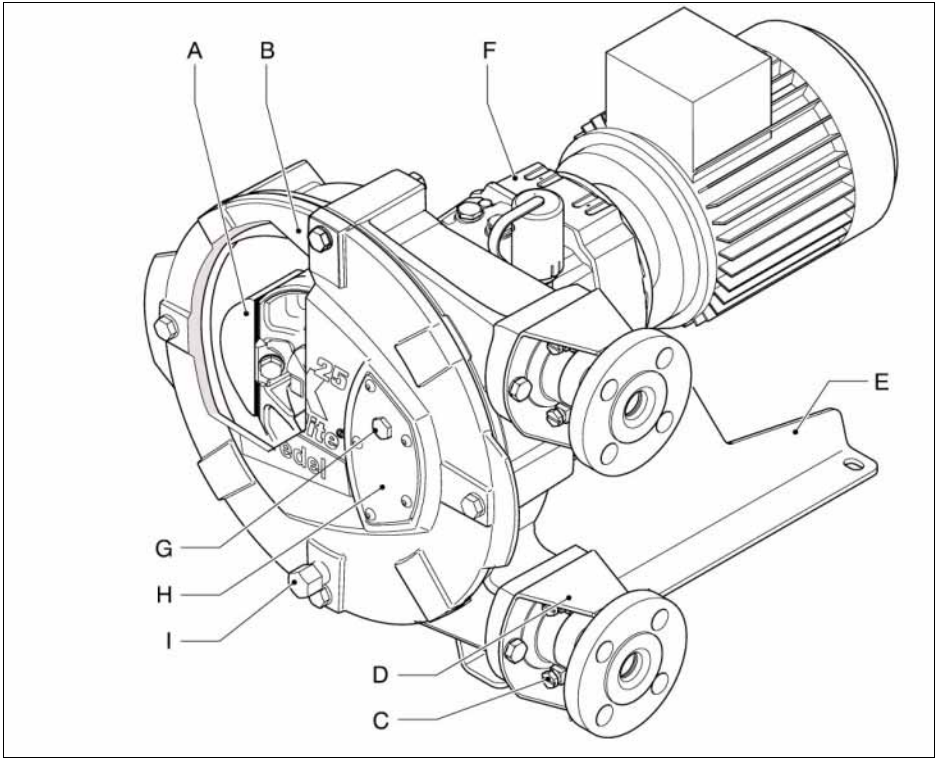

Pos	Description	Unit	Torques	
			SPX25 DuCoNite®	SPX32 DuCoNite®
A	Pressing shoe	Nm	64	64
		lbf in	566.4	566.4
B	Cover	Nm	50	50
		lbf in	442.5	442.5
C	Hose clamp	Nm	40	40
		lbf in	354	354
D	Flange bracket	Nm	50	50
		lbf in	442.5	442.5

Pos	Description	Unit	Torques	
			SPX25 <i>DuCoNite</i> [®]	SPX32 <i>DuCoNite</i> [®]
E	Support	Nm	25	85
		lbf in	221.2	752.2
F	Gearbox	Nm	25	50
		lbf in	221.2	442.5
G	Breather	Nm	3	3
		lbf in	26.5	26.5
H	Inspection Window	Nm	1.5	1.5
		lbf in	13.2	13.2
I	Drain	Nm	3	3
		lbf in	26.5	26.5

10.1.8 Shims specifications

- When the temperatures are above 140 °F always use one shim less than indicated in the diagrams.
- Always round up the number of shims.

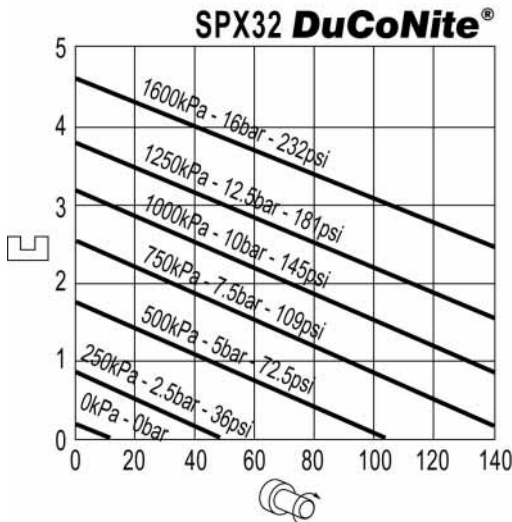
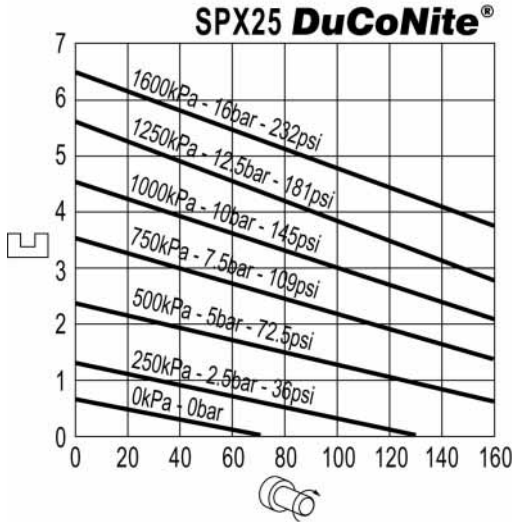

10.2 Lubricant table gearbox

Below is an overview of some of the recommended lubricants for the *co-axial* gearbox. In the majority of the cases, a mineral oil ISO VG 220 is recommended. In case of extreme ambient temperatures or a relatively wide range of ambient temperatures, a synthetic oil is recommended. Contact your Watson-Marlow Bredel representative for advice.

Recommended lubricants for the Watson-Marlow Bredel co-axial gearboxes			
Oil type	Mineral oil	Synthetic oil	
Change oil every	5000 hours	20,000 hours	
Ambient temperature	+14 °F to +104 °F	-40 °F to +176 °F	-22 °F to +140 °F
DIN (ISO)	CLP (CC)	CLP HC	CLP HC
ISO, NLGI	VG220	VG220	VG150
Mobil	Mobilgear 630	Mobil SHC 630	Mobil SHC 629
Shell	Shell Omala 220	Shell Omala 220 HD	
Klüber	Klüberoil GEM 1-220	Klübersynth GH4-220	Klübersynth EG 4-150
Aral	Aral Degol BG 220	Aral Degol PAS220	
BP	BP Energol GR-XP 220		
Tribol	Tribol 1100/220	Tribol 1510/220	
Texaco	Meropa 220	Pinnacle EP220	Pinnacle EP150
Optimol	Optigear BM 220	Optigear Synthetic A220	
Fuchs	Renolin CLP 220	Renolin Unisyn CLP220	

Recommended lubricants for the Watson-Marlow Bredel co-axial gearboxes			
Oil type	Synthetic oil		
Change oil every	20,000 hours		
Ambient temperature	-22 °F to +14 °F	-22 °F to +140 °F	-22 °F to +104 °F
DIN (ISO)	CLP HC	HCE	E
ISO, NLGI	VG32	VG460	VG460
		Foodgrade*	Biology**
Mobil	Mobil SHC 624		
Shell		Shell Cassida Fluid GL 460	
Klüber	Klüber-Summit HySyn FG32	Klüber oil 4UH1-460	Klüberbio CA2-460
Aral		Aral Eural Gear 460	Aral Degol BAB 460
Texaco	Cetus PAO 46		
Optimol		Optileb GT 460	Optisynt BS460

* For use in the foodstuffs industry. Meets the requirements of the USDA (United States Department of Agriculture): lubricant is suited for unforeseen contact with foodstuffs.

** Lubricant for use in agricultural areas and nature reserves.

10.3 Gearbox

Co-axial gearbox with helical gears. Standard as a 2 and 3 stage version.

Mounting position	IM 2001 (IM B35) foot flange gearbox with splined shaft in horizontal position.
Motor adapter	Electric motor has been integrated in the gearbox housing, by which the smallest possible dimension is achieved.
Optional motor adapter	Adapters in conformance with IEC-B5 or NEMA TC.

10.4 Electric motor

Standard electric motor design is an enclosed three-phase asynchronous motor. A thermal safety device to prevent motor overload is optional.



In case of doubt about the local applicable regulations for the drive connection, contact your Watson-Marlow Bredel representative.

Protection class	IP55/IK08
Insulation class	F
Increase in temperature	Within class B
Voltage/frequency	230/400 V - 3 phases - 50 Hz

10.5 Frequency controller

The frequency controller has been preprogrammed and only needs to be connected to the mains.

RFI filter	Integrated RFI filter B (industrial applications).
Control	Rotary knob for setting the speed and the keys for starting forward, stop and starting reverse.
Protection class	IP65
Mains power supply	There are 3 types available; the choice depends on the local electricity grid: <ul style="list-style-type: none"> • 200-240 V \pm 10%; 50/60 Hz \pm 5%; 1 ph • 200-240 V \pm 10%; 50/60 Hz \pm 5%; 3 ph • 400-480 V \pm 10%; 50/60 Hz \pm 5%; 3 ph

10.6 Parts list

10.6.1 Overview

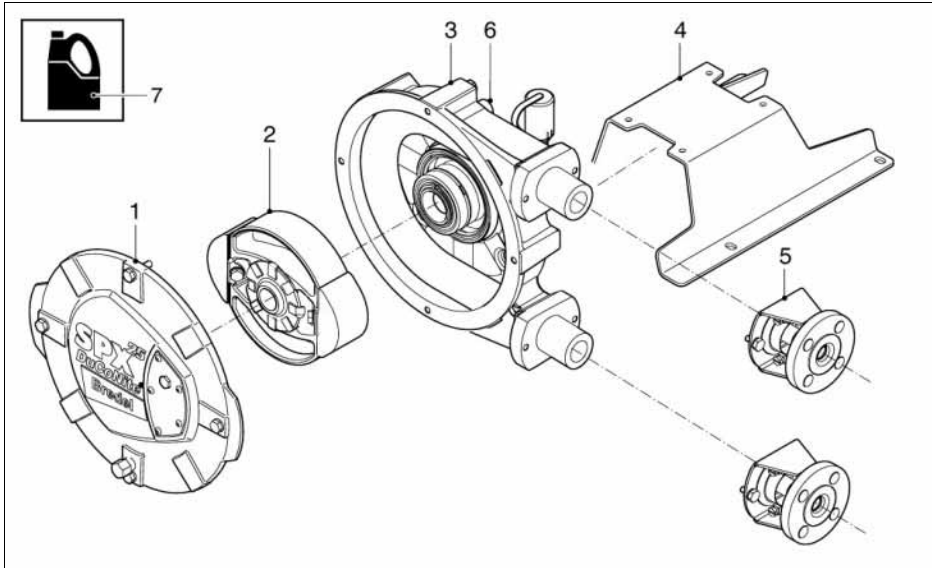

Pos.	Description
1	Cover assembly. Refer to § 10.6.2.
2	Rotor assembly. Refer to § 10.6.3.
3	Pump housing assembly. Refer to § 10.6.4.
4	Pump support assembly. Refer to § 10.6.5.
5	Flange assembly. Refer to § 10.6.6.
6	Revolution counter assembly. Refer to § 10.6.7.
7	Lubricants. Refer to § 10.6.8.

10.6.2 Cover assembly

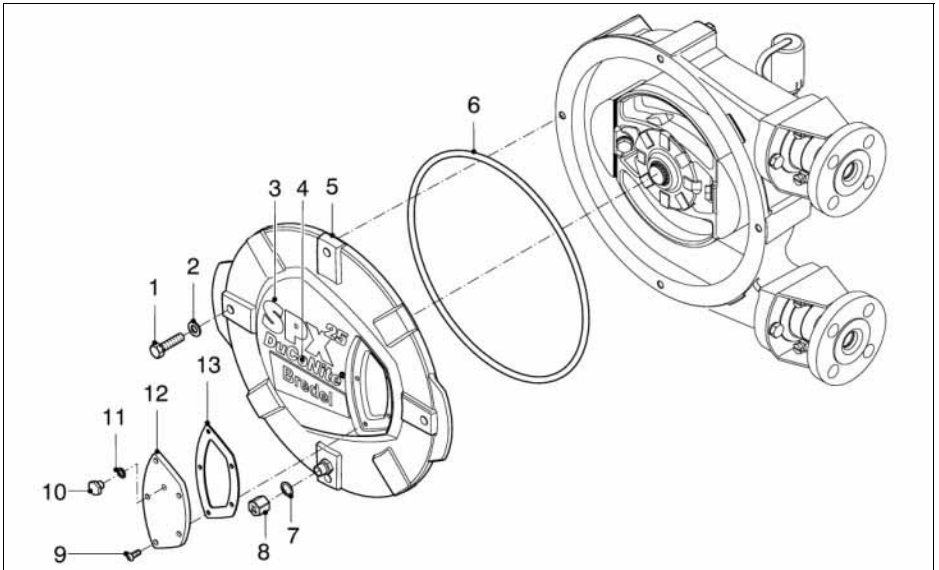

Pos.	Qty.	Description	Product codes for parts of pump type	
			SPX25 <i>DuCoNite</i> [®]	SPX32 <i>DuCoNite</i> [®]
1	4	Bolt, hex. head, M10X40	F502045	F502045
2	4	Washer, M10	F523013	F523013
3	1	SPX sticker	225238	232238
4	1	<i>DuCoNite</i> [®] sticker	225239	232239
5	1	Cover <i>DuCoNite</i> [®]	225102N	232102N
6	1	Quad ring	225123	232123
7	1	Gasket	29017349	29017349
8	1	Drain plug	29025348	29025348
9	5	Round head screw, M6X16	F552536	-
	6		-	F552536
10	1	Breather plug	29017463	29017463
11	1	O-ring	S120113	S120113
12	1	Inspection window	225155N	232155N
13	1	Gasket	225156	232156N

10.6.3 Rotor assembly

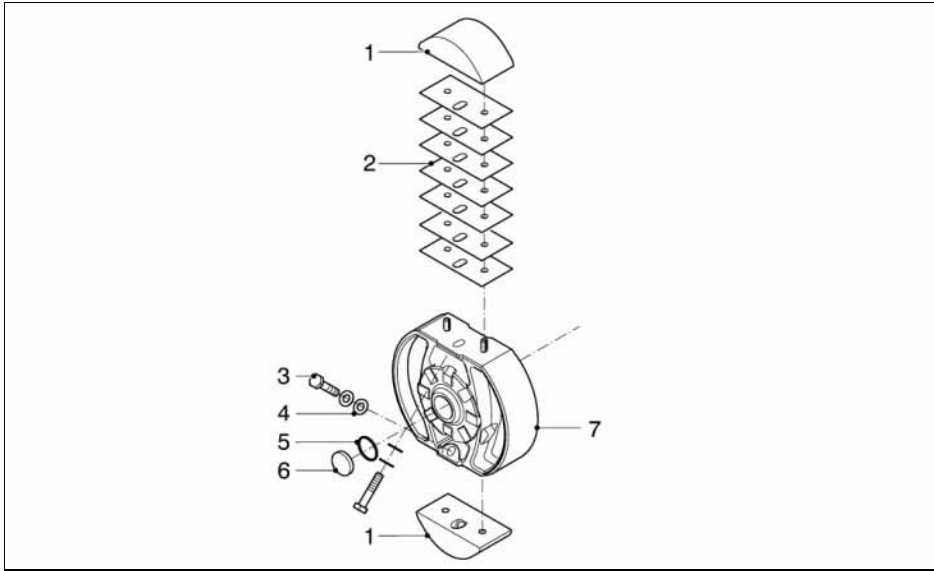

Pos.	Qty.	Description	Product codes for parts of pump type	
			SPX25 <i>DuCoNite</i> [®]	SPX32 <i>DuCoNite</i> [®]
1	2	Pressing shoe	225109	225109
		Pressing shoe with titanium inserts	225109N	225109N
2	14	Shim	225107	-
	10		-	232107
	14	Shim, titanium	225107N	-
	10		-	232107N
3	2	Bolt, hex. head, M10X50	F502047	F502047
		Bolt, hex. head, M10X50 titanium	F504080-1	F504080-1
4	2	Nord-Lock ring, M10	F349506	F349506
		Washer, M10 titanium	F523013-1	F523013-1
5	1	O-ring	S120263	S120263
6	1	Sealing cap	29035456	29035456
7	1	Rotor <i>DuCoNite</i> [®]	225103N	232103N

10.6.4 Pump housing assembly

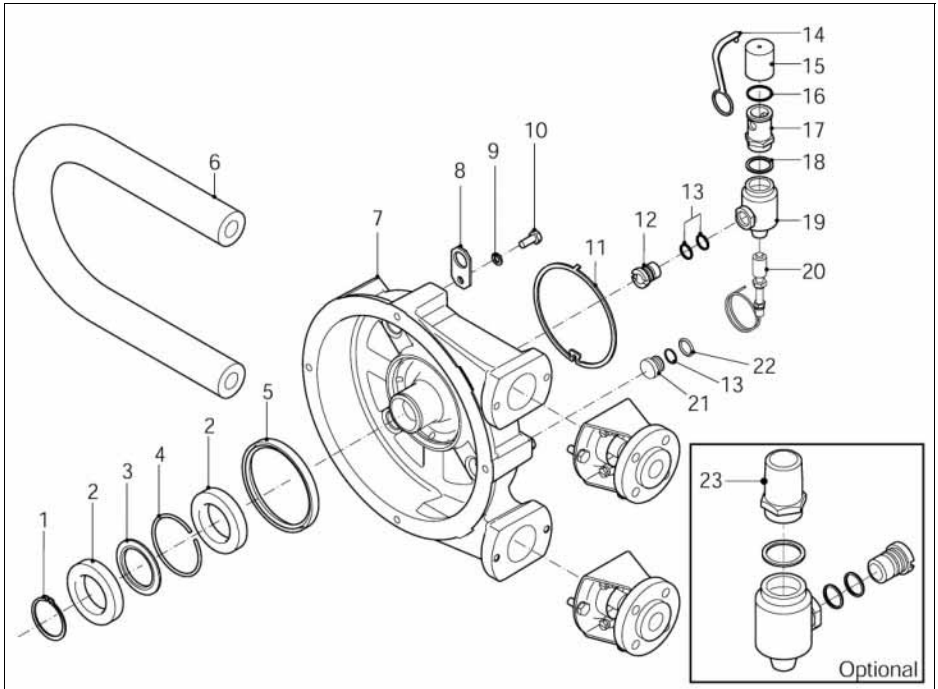

Pos.	Qty.	Description	Product codes for parts of pump type	
			SPX25 <i>DuCoNite</i> [®]	SPX32 <i>DuCoNite</i> [®]
1	1	Circlip, A60	F343049	F343049
2	2	Bearing	B141260	B141260
3	1	Spacer ring	29085201	29085201
4	1	Retaining circlip	29095297	29095297
6	1	NR	025020	032020
	1	NBR	025040	032040
	1	CSM	025070	032070
	1	EPDM	025075	032075
7	1	Pump housing <i>DuCoNite</i> [®]	225101N	232101N
8	1	Lifting strip	29065361	29065361

Pos.	Qty.	Description	Product codes for parts of pump type	
			SPX25 <i>DuCoNite</i> [®]	SPX32 <i>DuCoNite</i> [®]
9	1	Bolt, hex. head, M10X25	F504075	F504075
10	1	Washer, Spring Lock, M10	F532010	F532010
11	1	Seal	225114	232114
12	1	Breather connection plug	29034451	29034451
13	5	O-ring	S120183	S120183
14	1	Breather strip	29210222	29210222
15	1	Breather cap	29045221	29045221
16	1	O-ring	S120263	S120263
17	1	Breather pipe	29060453	29060453
18	1	Gasket	29038352	29038352
19	1	Breather housing	29086450	29086450
20	1	High level switch	900610	900610
21	3	Plug	29029455	29029455
22	3	O-ring	S122113	S122113
23	1	Drain pipe	29060454	29060454

10.6.5 Support assembly

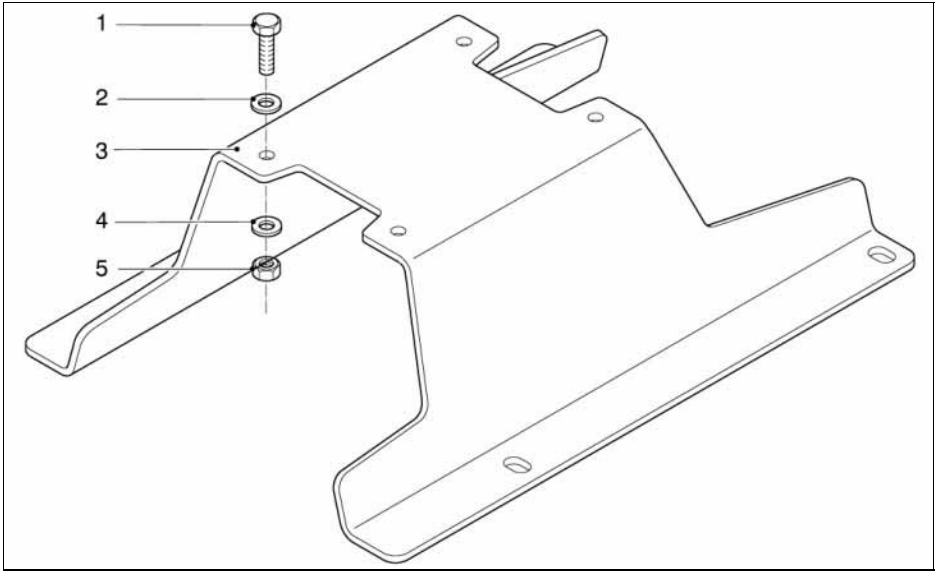

Pos.	Qty.	Description	Product codes for parts of pump type	
			SPX25 <i>DuCoNite</i> [®]	SPX32 <i>DuCoNite</i> [®]
1	1	Pump support	225106A	232106A
2	4	Bolt, hex. head, M8X35	F504057	-
		Bolt, hex. head, M12x45	-	F502067
3	4	Washer, M8	F523012	-
		Washer, M12	-	F523014
4	4	Washer, Spring Lock, M8	F532009	-
		Washer, Spring Lock, M12	-	F532011
5	4	Nut, M8	F516012	-
		Nut, M12	-	F516014

10.6.6 Flange assembly

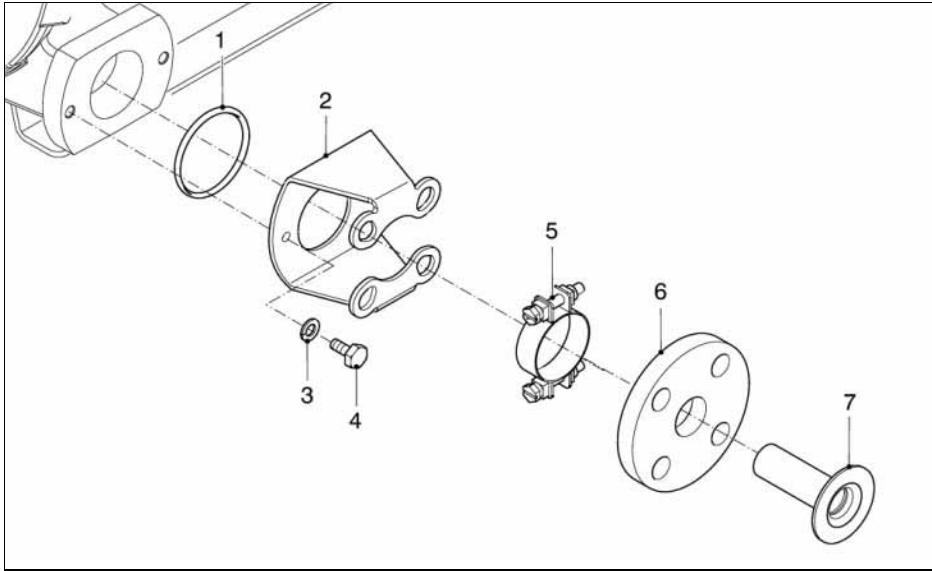

Pos.	Qty.	Description	Product codes for parts of pump type	
			SPX25 DuCoNite®	SPX32 DuCoNite®
1	2	Flange bracket	225197A	232197A
2	2	O-ring	S112233	S112273
3	4	Bolt, hex. head, M10X25	F504075	F504075
4	4	Washer, Spring Lock, M10	F532010	F532010
5	2	Hose clamp	C122505	C122505
6	2	Flange, DIN SS	225199	232199
		Flange, ANSI SS	225199A	232199A
7	2	Insert, Stainless steel	025186	032186
		Insert, PVC	025187	032187
		Insert, PP	025189	032189
		Insert, PVDF	025190	032190

10.6.7 Revolution counter assembly

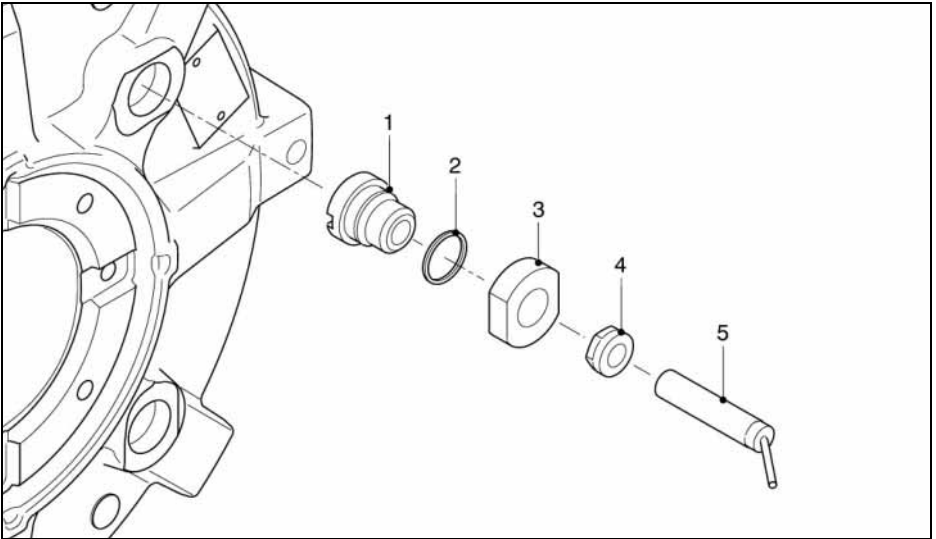

Pos.	Qty.	Description	Product codes for parts of pump type	
			SPX25 <i>DuCoNite</i> [®]	SPX32 <i>DuCoNite</i> [®]
1	1	Plug	29029457	29029457
2	1	O-ring	S120183	S120183
3	1	Nut	29035458	29035458
4	1	Revolution counter shim	225107NS	232107NS
5	1	Revolution counter	29050368	29050368

10.6.8 Lubricants

Pos.	Qty.	Description	Product codes for parts of pump type	
			SPX25 <i>DuCoNite</i> [®]	SPX32 <i>DuCoNite</i> [®]
1	1	2 l (0.5 gal) can Watson-Marlow Bredel Genuine Hose Lubricant	902143	-
	1	3 l (0.8 gal) can Watson-Marlow Bredel Genuine Hose Lubricant	-	908143

Watson-Marlow Pumps Group
37 Upton Technology Park
Wilmington, MA 01887
USA

Telephone: 800 - 282 - 8823
978 - 658 - 6168

Fax: 978 - 658 - 0041

Internet: www.wmpg.com

E-mail: support@wmpg.us



© 2010 Watson-Marlow Bredel B.V.