

# FMB210

## FULLY AUTOMATIC MONOBLOC

- Compact / small foot print
- Very suitable for GMP environments
- Up to 75 units/minute
- Short change-over time
- Customized design



WORLD LEADERS IN ASEPTIC PERISTALTIC FILLING



FMB210 is equipped with a number of sensors, to ensure correct operation and to ensure that a missing bottle results in no subsequent fill/cap.

FMB210 is equipped with a central tool platform, which carries all capping tools. This platform is balanced, which makes it extremely easy to change from one format to another.



FMB210 can be supplied both with or without a class 100 laminar flow unit (LAF) to ensure a safety class 100 production of injection liquids or other types of products. A standard LAF unit can be delivered for the machine

base and an extended LAF unit can be customized to cover either the rotary infeed table for glass vials/eye drop bottles or the outfeed tray for lyophilisation applications.



FMB210 can be equipped with a »one disc roller head« for closing sterile aluminium cap overseals. This system generates only a minimum of particles, and most importantly, no air turbulence. The machine is entirely suitable for use in a class 100 room.

FMB210 is equipped with the unique Watson-Marlow Flexicon peristaltic filling system, called the Multi Filling System. This system ensures a complete closed fluid path, where the product is only in contact with the silicone tube and the stainless steel needle.



## FMB210 FULLY AUTOMATIC MONOBLOC

### FMB210

The new FMB210 is not only a filling machine, but a complete concept for fully automated production in small and medium scale production scenarios. This is based on a design featuring modular tool blocks for different applications.

### Applications

FMB210 is a new option for the pharmaceutical industry for sterile filling and capping of vials and is designed especially for the small and medium sized sterile production with a high frequency of product changes. This makes FMB210 a very attractive solution for a large number of applications such as lyophilisation, diagnostics kits, bio-tech products, injection liquids and eye drops.

This fully automatic monobloc is ideal for very flexible and »just in time« filling and capping of sterile liquids and meets the latest GMP standards.

FMB210 is also perfect for the production of clinical trial batches.

### Machine principle

The vials are processed by means of a ten slot star wheel, which positions the vials with great stability and accuracy in the different working stations. The star wheel indexing system is specially developed to meet the demands for accurate

positioning and gentle handling of the vials by accelerated and decelerated movements and a very rapid quick indexing.

The indexing speed is independent of the operations at the different work stations, ensuring that FMB210 automatically finds the highest output.

### Machine base

FMB210 features a very stable and robust machine base, which is covered by stainless steel. Star wheel, infeed scroll, bottle track and tools are all mounted on columns of a special »easy to clean« design allowing the operator access to clean underneath all parts – without machine dismantling.

The base cabinet contains the unique Watson-Marlow Flexicon indexing system, the balance systems for vibrator and tool platform as well as all pneumatic components.

### Filling system

FMB210 is equipped with the special Watson-Marlow Flexicon Multi Filling System peristaltic fillers and the vials are filled over two filling stations. The peristaltic system is a completely closed system from the bulk product container to the end of the filling needle. The product is only in contact with the medically graded silicone tubing and the filling needle,

which ensures no risk of cross contamination during product changes. Furthermore, the special microprocessor control system enables printing of production documentation and saving of complete sets of filling parameters. In addition to these features, the Watson-Marlow Flexicon quick-change pump head offers the operator a safe product change in less than 5 minutes.

With the Watson-Marlow Flexicon Multi Filling System, the same pump can fill from 0.1 ml to more than 100 ml, just by changing the tube size.

### Tool platform and vibrators

FMB210 is equipped with the special Watson-Marlow Flexicon designed tool mounting, which has a central tool platform balanced by air cylinders, allowing the operator to change the formats very easily.

The adjustment of the tool height is done in one operation simply by placing a rod underneath the tool platform and pressing the platform down against this rod. The height adjustment of the vibrators is done according to the same principle. This is the reason why vials and cap change-over can be done in less than 10 minutes.

## FMB210 TECHNICAL SPECIFICATIONS

### »One disk roller head« closing

This aluminium cap closing system provides a very attractive alternative to the traditional spinning head which may release a significant amount of particles and generate air turbulence due to the turning action.

The advantages of the »one disk roller head« are:

- higher output – up to 75 vials per minute
- very low generation of particles
- less maintenance required
- high reliability in relation to cap quality
- nice appearance of the closed caps, due to gentle forming.

FDA validated sterile production is today carried out on Watson-Marlow Flexicon monobloc machines where filling, stoppering and oversealing are done in the same run. Therefore, both investment and space are saved by all Watson-Marlow Flexicon's pharmaceutical customers.

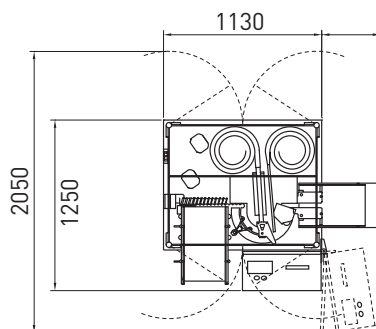

### Optional vial/bottle feeding

Watson-Marlow Flexicon offers three different options for vial/bottle feeding: timing screw, rotary table or automatic plastic bottle unscrambler. The timing screw is ideal for small vials in sterile production, whilst the rotary table is an attractive solution for applications with larger glass or plastic bottles in many different sizes. The automatic bottle unscrambler is ideal for applications with plastic bottles.

### Machine guarding

When FMB210 is fitted with LAF the machine guarding is an integrated part of the LAF support. By optimum design of openings in the guarding, the laminar airflow on FMB210 provides maximum protection of open vials.

### FMB210 for isolator technology

The FMB210 machine can be delivered in a very special design for integration into an isolator. For further information regarding this option, please contact Watson-Marlow Flexicon directly or Watson-Marlow Flexicon's local distributor.

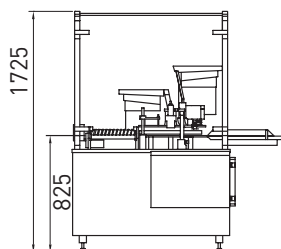

### Applications:

- Filling, insertion of rubber stoppers and oversealing of aluminium caps
- Filling and half stoppering of lyophilisation stoppers. Placing and closing of the aluminium overseal in second run. All operations on the same machine
- Filling and screw capping
- Filling, insertion of dropper tips and screw capping
- Filling and capping of micro test tubes
- Filling and capping with press caps

### Capacity:

Machine capacity depends on filling volumes, but the following figures are max. capacities:

### Injection application:

Up to 75 units per minute

### Lyophilisation application:

Up to 85 units per minute

### Screw capping application:

Up to 40 units per minute

### Mains:

200 to 240 VAC single phase and earth

### Power consumption:

Max. 1500 W

### Pneumatic connection:

7 bar clean and dry air

### Air consumption:

Depends on the application

### Machine finish:

»Silk surface« stainless steel, anodised aluminium and plastic

### Ingress protection:

IP54

### Weight:

Depends on the application, but typically 650 kg